

CONTENTS	Page
Important Notice	3
Safety-technical Remarks	
- Regulations	3
Product Safety	4
- Electrical Safety	4
- Mechanical Safety	4
- Crush Zones	4
- Radiation Safety	5
- Explosion Protection	6
- Electromagnetic Interference (EMI)	6
- Classification per IEC 601-1-1	6
- EC Conformance	6
- Environmental Conditions for Operation	6
- Disposal	6
Design Features	
- Design	7
General	
- Brief Description	8
- Applicability	9
- Important Note	9
Installation	
- Required Area	10
- Room Height	10
- Connection	10
- AI Equivalency Value	10
Control Elements	
- Location	11
- Explanation of Symbols/Function	12
- Setting the Exposure Position/Exposure	13
- Optional Accessories	14
Maintenance	
- Important Notice	16
- Testing by the Operator	16
- Testing by Customer Service	16
- Cleaing	17
- Disinfection	17
- EEC Guideline 93142 Regarding Medical Products	17
Placement of Model Labels	
- Labeling	18

IMPORTANT NOTICE

Proper use of this product by operating personnel requires knowledge of these **OPERATING INSTRUCTIONS**; these must be studied prior to starting up the equipment.

This radiographic equipment may be operated only by personnel who possess the required specialized knowledge of radiation safety or who are familiar with radiation safety and who have been instructed in the operation of the radiographic equipment.

The operator is always responsible for maintaining the regulations that apply for operation of the radiographic equipment.

SAFETY-TECHNICAL REMARKS

Regulations

If there are legally specified regulations regarding the operation of radiographic equipment, it is the responsibility of the operator to observe them.

In the interest of safety for patient, operating personnel as well as for third parties, tests which assure the operating reliability and functionality of the product must be performed in accordance with the Maintenance Instructions in intervals of 12 months.

We request that you contact your customer service department regarding performance of these tests.

If tests are required in shorter intervals in order to comply with national specifications or regulations, it is absolutely necessary to observe them.

Modifications and additions made to the product must be in accordance with legal regulations as well as with generally accepted rules of the technology.

As the manufacturer of the radiographic equipment, we can assume responsibility for the safety-technical features of the product only if:

any maintenance, repair and modification on it is carried out only by us or by facilities that have been authorized by us for this purpose, and if there is a failure of parts which affect the safety of the product, such parts are replaced with original spare parts.

When performing this work, we recommend that written confirmation regarding the nature and extent of work be requested from the person performing the work, and if applicable, include any changes made in nominal values or to the operating range. In addition, the company performing the work, the date and a signature should be included.

Prior to daily use, the user must assure himself that all devices provided for safety are functional and that the product is operational.

If the operator of the radiographic equipment wishes to combine it with other products, components or assemblies, and this capability is not clear from the technical data, he must assure that the safety of patients as well as of operating personnel is not adversely affected by the intended combination by contacting us as the manufacturer of the equipment or by contacting someone who has specialized knowledge of the equipment.

PRODUCT SAFETY

Electrical Safety

Only specially trained maintenance personnel may remove the covers and panels on the radiographic equipment.

This radiographic product may be operated only in medical rooms which meet the requirements of VDE 0107.

It is designed for a permanent connection with universal isolation from the power source (IEC 601, Chap. 57.1).

Mechanical Safety

Please make sure that neither the patient nor you can reach into the movement path of the radiographic equipment or that parts of clothing can be caught by it.

Make sure that all objects within the movement range of the radiographic equipment have been removed.

Crush Zones

The highlighted locations in the following sketch represent the danger zones in which the patient or operator can be injured by crushing or striking.

See following page.

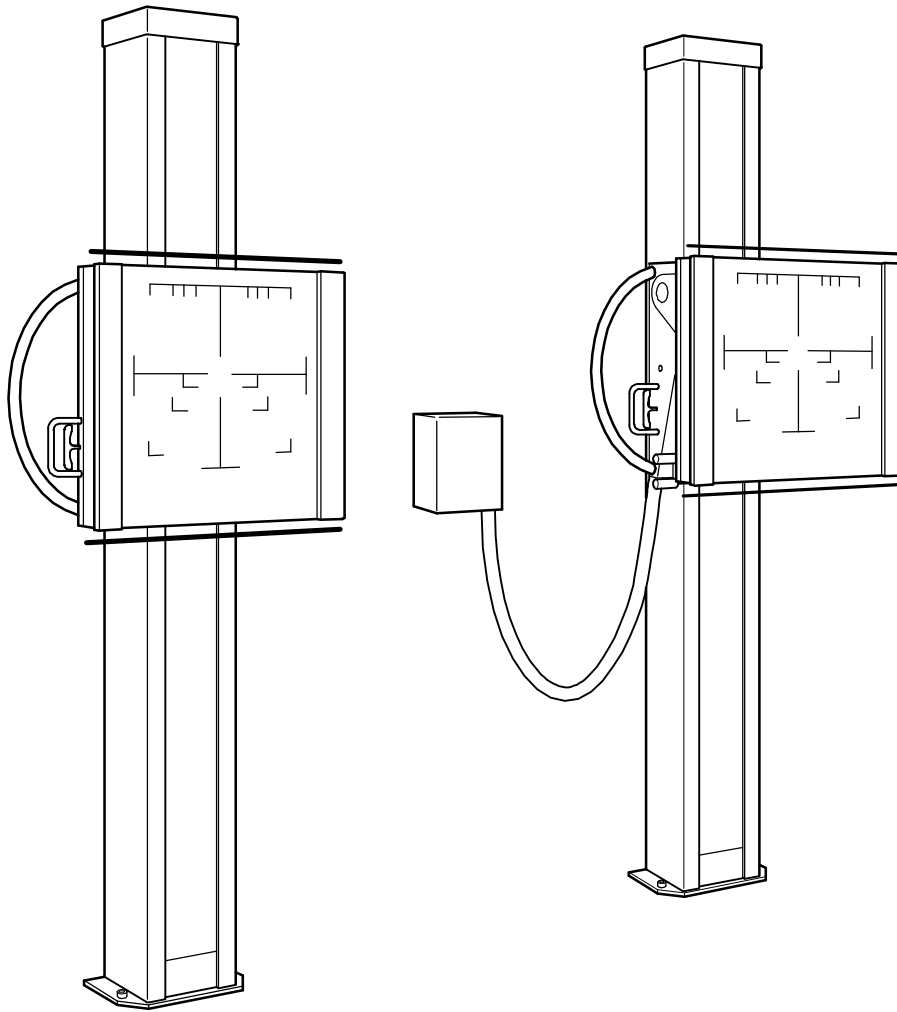

Radiation Safety

The equipment does not have any control elements with which radiation can be triggered. Triggering of exposure is made from the generator radiation-protected location. The general regulations regarding radiation safety must be observed.

We also recommend:

1. Keep the tube current as low as possible.
2. Keep the radiation field as small as possible.
3. Maintain the max. possible distance.
4. Do not forget to provide radiation protection for the patient.

Explosion Protection

This product is not intended for use in areas where there is a risk of explosion. Only those household cleaning products whose gas-air mixture is inflammable may be used.

Electromagnetic Interference (EMI)

The product meets EMI specifications as defined in EEC Guideline 89/336. The limit values for measurement of interference per EN 55011, Group 1, Class B and the requirements for immunity to interference per EN 50082-1, Degrees 2 and 5 are maintained.

Classification per IEC 601-1-1

Depending on the type of protection against electrical shock, the equipment corresponds to Safety Class 1 and, depending on the degree of protection, Type B.

EC Conformance



This radiographic equipment meets basic requirements per the specifications of EEG Guideline 93/42 and the recommendations regarding medical products per Article 11, Paragraph 5 and the procedure described in Appendix VII.

The CE symbol is valid only for the product without the radiographic components.

Further information can be obtained upon request from:

Hans Pausch
Röntgengerätebau
Qualitätssicherung

Postfach 28 60
D-91016 Erlangen

Fax: ..49 9131 99 24 22

Environmental Conditions for Operation

Ambient temperature range	10° C to 40° C
Ambient relative humidity	20% to 80%
Ambient atmospheric pressure	700 hPa to 1100 hPa

Disposal

Legal disposal regulations may exist for this product. To avoid environmental and human damage, we request that you contact your customer service department before the product is taken permanently out of operation.

Design Features

Design

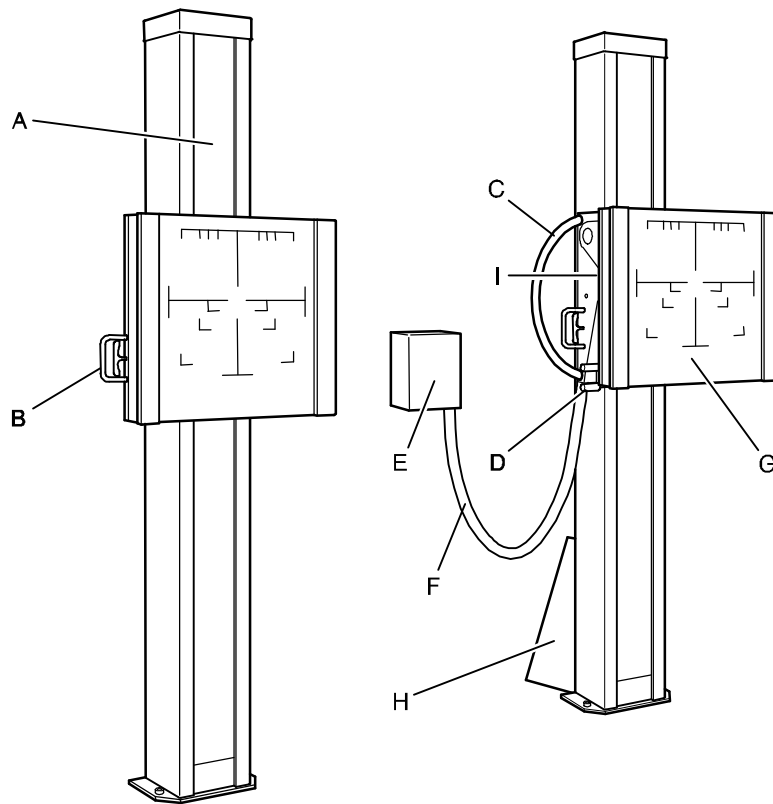

- A** Stand column
- B** Brake grip
- C** Patient handgrip
- D** Tilt grip
- E** Wall terminal box
- F** Flexible hose
- G** Front panel profile rail for accessories
- H** Kit for free-standing version
- I** Angle indicator
- Optional** Spacer (Version V only)
- Optional** Patient extender grip

General

Brief Description

Version V

The stands are used to make exposures on an adjustable Bucky. The stand is designed for installation of a P adjustable Bucky, as well as for the LF, the Philips, the Toshiba, the Yamato and the Midwest adjustable Bucky.

The adjustable Bucky can be moved using the vertical carriage in a range from 380 mm to 1900 mm above the floor.

The vertical carriage, including the adjustable Bucky, is floating weight-compensated and is mechanically braked in each position.

The ergonomically-shaped brake grip can be released with one hand while the adjustable Bucky is moved vertically.

The vertical movement range (center of cassette) is at least 380 mm and is max. 1900 mm above the floor. The distance between the wall and the front panel is 425 mm.

Version VK

In addition to the functions described above, with version VK, the adjustable Bucky can be freely pivoted from the vertical position to the horizontal position to 90° or to -20°. The scale of the angle indicator is in the user's field of view and is graduated in steps of 20°. The distance of the wall-front panel is 680 mm, inclusive wall terminal box with flexible hose and cable.

Note

Installation can be made on the wall or can be freely set up in the room using the free-standing kit.

If not ordered differently, the stands are shipped for left-hand operation (with brake grips installed on the operator's left side).

Repositioning the grips is possible on site and can be done by service.

Options - Accessories

Spacer

To make exposures of a sitting patient easier, a spacer between the carriage and the adjustable Bucky can be installed in the Version V. This spacer is optional.

Tracking Control

Tracking control and thus automatic positioning of the source-to-image distance (SID) can be switched on and off at the stand by pressing a key. Indication is made by means of a lamp in the key.

Patient Extender Grip

Both Bucky stands can be equipped with patient extender grip; this can be used optionally on the left or right and provides the patient with a secure hold.

Patient Handgrips

Both Bucky stands can be equipped with patient handgrips (grip handles).

Free-standing Installation Kit

Free-standing installation in the room can be made using the kit.

Front Panel with Reinforcement Frame

The front panel is used to cover the Bucky and is equipped with a side T-slot rail to attach accessories.

Babyx Holder with Hook

The hook on the Babyx holder is used to accept the Babyx cover and is height-adjustable. The Babyx holder can be pivoted into a park position.

Area of Application

Exposures of standing and sitting patients from the head to the knee.

Important Note

Proper use of this product requires that operating personnel be familiar with the operating instructions. They should be carefully studied prior to starting up the equipment. The section entitled, "Safety-technical Information", should be given particular attention.

Installation

Required Area

The unit is designed for stationary operation. The space required for this is approx. 130 cm x 100 cm.

Room Height

The height of the column stand is 230 cm. However, the room height required for installation should be 235 cm.

Connection

The stand does not require any electrical connections. Only the ground wire connection must conform to VDE 0107. The instructions of the particular manufacturer should be observed for connection of the Bucky.

Al Equivalency Value

The attenuation equivalency value of the front panel is 0.6 mm.

This is measured in accordance with:

DIN EN 60601-1-1-3 at 100 kV and a half-value layer of 3.7 mm Al

and FDA 21 CFR § 1020.30 (n) at 100 kV and a half-value layer of 2.7 mm Al.

Control Elements

Location

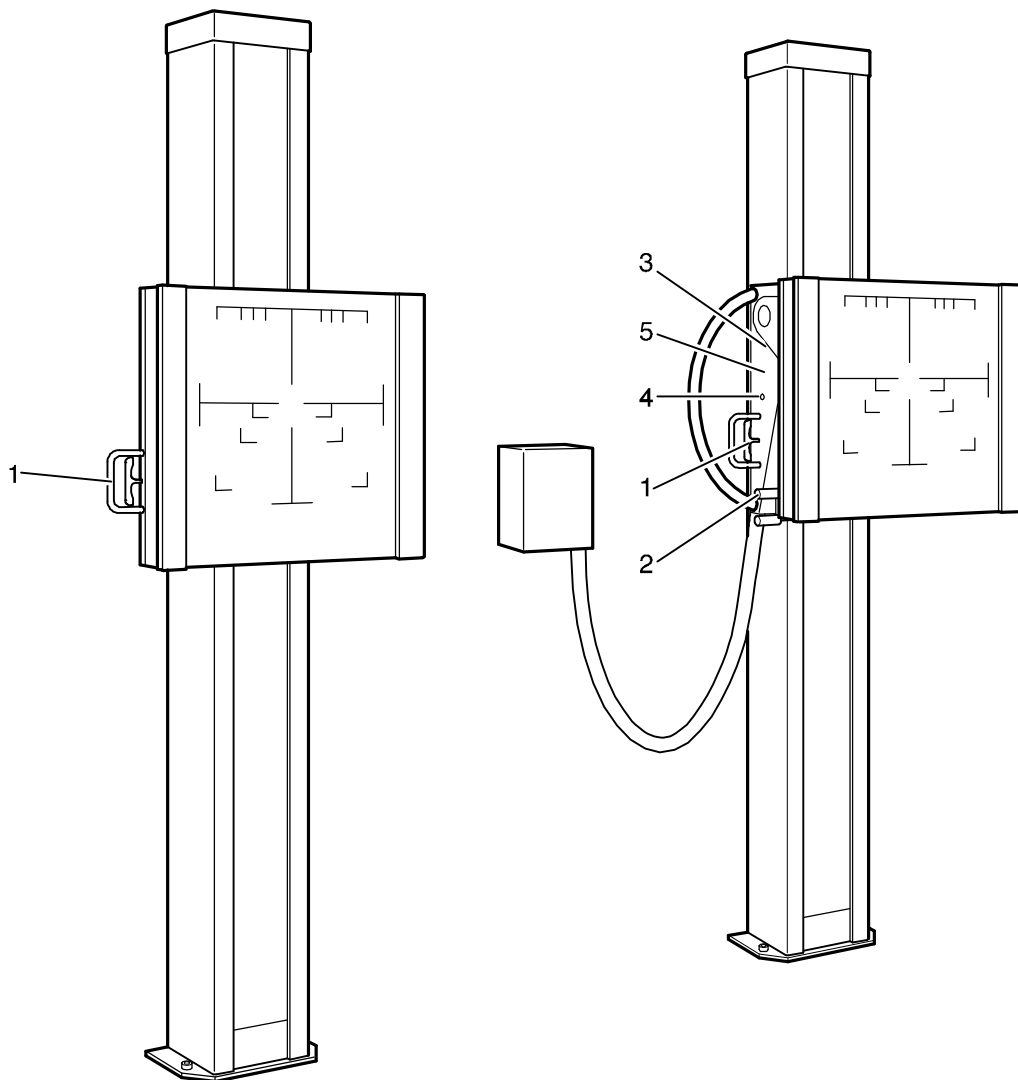

- 1 Vertical brake grip
- 2 Tilt grip
- 3 Angle indicator
- 4 SID switch
- 5 Signal lamp

Control Elements

Explanation of Symbols/Function

Depending on the version, the control elements can be located on the left or on the right.

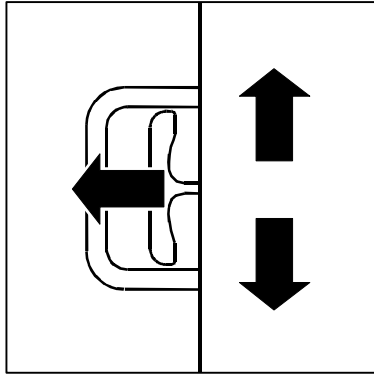

Moving the adjustable Bucky vertically

Pull the brake grip, move the adjustable Bucky vertically and release the brake grip when the Bucky is in the desired position.

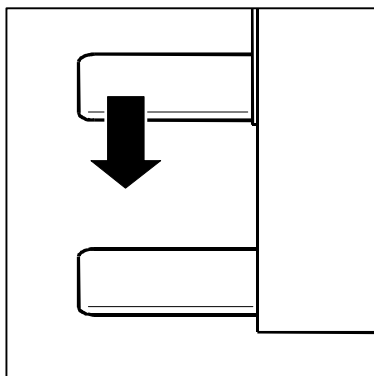

Tilting the adjustable Bucky to +90° or -20°

Version VK only

Squeeze the tilt grips together and tilt the adjustable Bucky into the desired position between +90° and -20°.

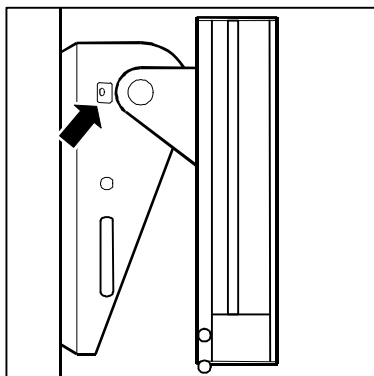

Angle Indicator Version VK only

Display of the tilt angle from +90° to -20°.

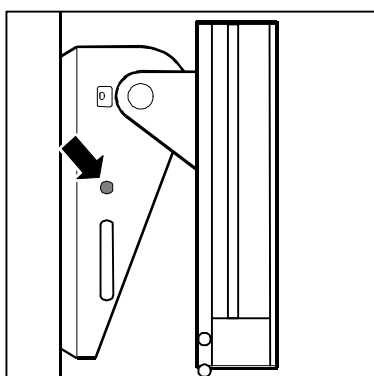

SID Switch Version VK only

If wished, the stand can be shipped with an SID switch for exposures for sensing the position in the vertical beam direction.

If the opened adjustable Bucky is moved down, the switch is activated at a preset distance from the floor.

The distance to the floor can be set in a range from 755 mm to 685 mm.

Indication is achieved by means of a lamp in the key.

Setting the Exposure Position / Exposure

Setting the Exposure Position for Version V

Release the vertical brake by squeezing the brake grip and move the adjustable Bucky into the height position of the exposure subject.

Position the patient in front of the adjustable Bucky.

Set the tube unit SID and adjust the exposure field using the light field in the collimator.

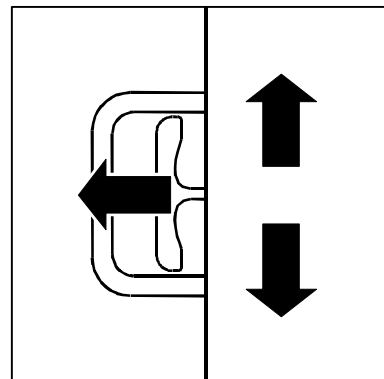

Setting the Exposure Position for Version VK

With the VK Version, the adjustable Bucky can also be tilted - 90° and 20°.

Release the vertical brake by pulling the brake grip and move the adjustable Bucky into the height position of the exposure subject.

Release the tilt brake by pulling the tilt grip and position the adjustable Bucky at the desired tilt angle.

Position the patient in front of the adjustable Bucky.

Set the tube unit SID and adjust the exposure field using the light field in the collimator.

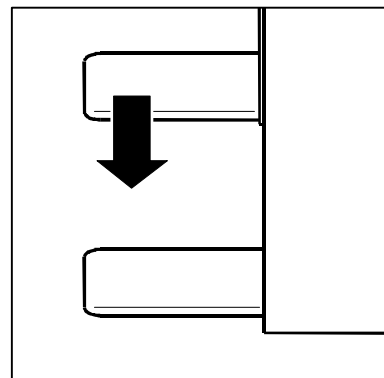

Preparing an Exposure

Insert a cassette.

Set the exposure data at the console.

Check to make sure everything is ready for exposure.

Instruct the patient: Please take a breath and hold it!

Trigger exposure.

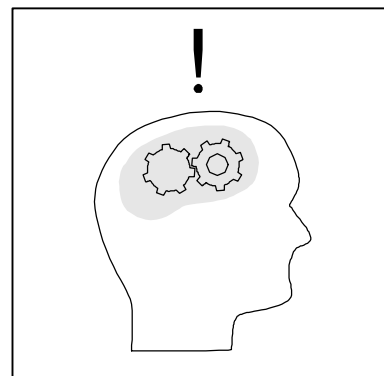

Note

Do not forget radiation protective measures for the patient (lead rubber apron, gonad protector, etc.)!

Accessories

Compression band / head rest / cassette holder / patient extender grip / Babyx holder with hook

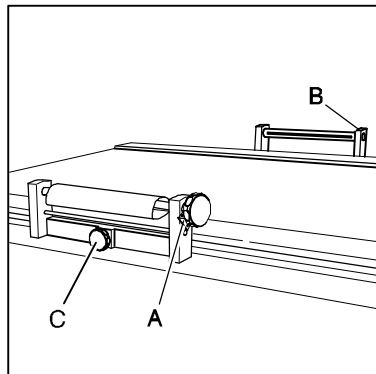

Compression band

Install

Insert take-up roll **B** into the wall-side profile rail in the tabletop. Secure it in the working position using the knob on the opposite side.

Insert tensioner **A** into the front rail. Secure the tensioner in the working position opposite the take-up **B** with knob **C**.

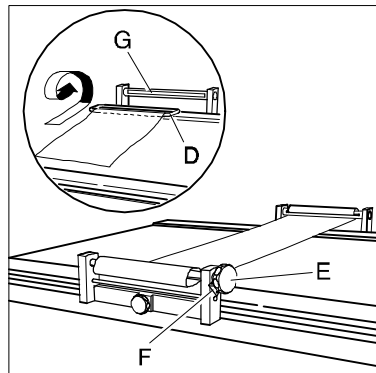

Press the release latch **F**. Unroll the band and stretch it across the patient.

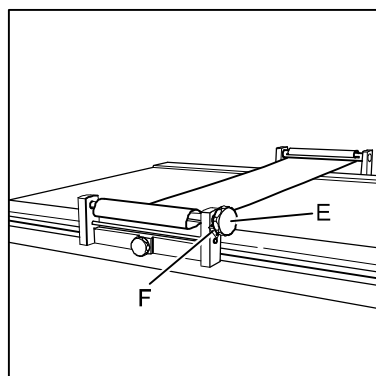

Wrap the stretch band once around the shaft of the take-up roll.

Insert bow **D** into the slot of shaft **G**. Turn knob **E** and roll up/tension the compression band.

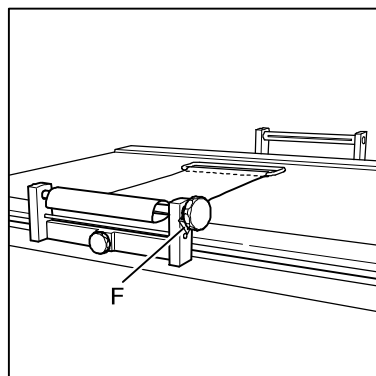

To release the band

Press release latch **F**.

Head Rest

The holder for the head rest is inserted into the side profile rail of the front panel. The holder can be secured in any desired working position. The padded support plate is used to stabilize the patient in the required exposure position.

Handscrew **A**: Secure the holder on the tabletop

Handscrew **B**: Secure the support arm

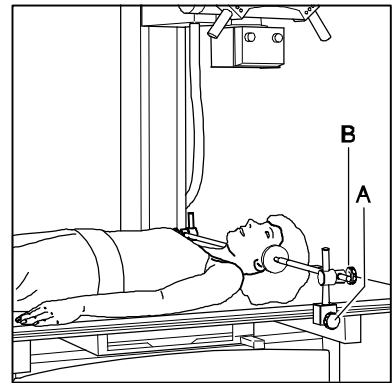

Cassette Holder

The cassette holder for cassettes from 13x18 to 35x43 cm is hooked into the two profile rails above the front panel.

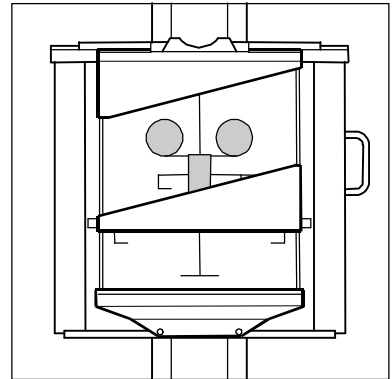

Patient Extender Grip

The patient extender grip can be inserted either on the left or right in the support frame of the adjustable Bucky.

The angle of the grip bar can be adjusted after pulling the pivot shaft forward. The grip bar snaps back into the desired position after it is released.

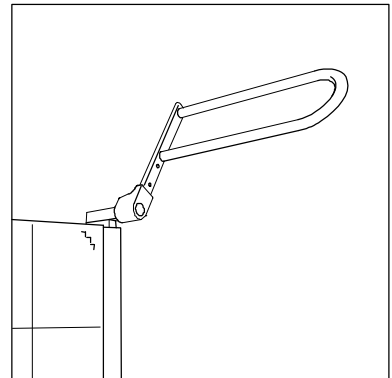

Babyx Holder with Hook

The hook on the Babyx holder is used to accept the Babyx cover and is height-adjustable. The Babyx holder can be pivoted into a park position.

Place the baby in the Babyx holder, attach the cover to the hook and move the holder into the exposure position.

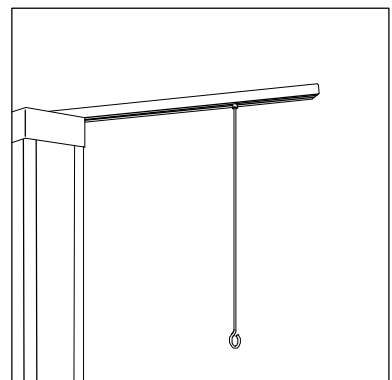

MAINTENANCE

Important Note

As with every piece of technical equipment, this radiographic unit requires regular maintenance and upkeep to assure the operating reliability of the unit.

Operator Testing

The operator must test the radiographic unit as described below.

If there are malfunctions or other differences from normal operating behavior, switch off the unit immediately and inform customer service.

The unit may be put back into operation again only after all malfunctions have been corrected.

Daily Checks

Indicator lamps, operating elements, labels and warning labels.

Weekly Checks

All cables and their connections.

Checks by Customer Service

To achieve problem-free operation of the BS 2000, as well as to achieve safety for patients and for operating personnel, technical maintenance must be performed by customer service in intervals of 12 months.

See "Technical Maintenance" in the installation instructions.

As part of this, it is required that the steel cable in the stand be replaced every 3 years.

Caution

If there are parts failures which affect the safety of the unit, original replacement parts must be used.

We recommend that when this work is performed, written confirmation be obtained about the type and extent of the work, and if applicable, with a statement about any changes that have been made to nominal data or about the working range, as well as with the date, name of the company performing the work and a signature.

CLEANING

Switch off the system prior to cleaning it.

Plastic surfaces may be cleaned only with a solution of soapy water because other agents (e.g. with high alcohol content) can dull or cause cracking of the surface.

No caustic, solvent or scouring cleansers or polishes may be used. Water or other liquids may not get into the unit to avoid short-circuits in the electrical installation and corrosion of parts.

Painted parts and aluminum surfaces may be moistened only with a damp cloth and a mild cleaning agent and wiped down with a soft cloth.

Chromed parts may only be wiped down with a soft, dry cloth.

DISINFECTION

Switch off the system prior to disinfecting it.

Only those disinfection methods that meet the applicable regulations and guidelines as well as explosion safety may be used.

No caustic, solvent or gaseous disinfectants may be used.

Spray disinfection is not recommended because if it is, disinfectants can get into the radiographic unit.

EEC Guidelines 93142 regarding M

Article 12

Special Procedure for Systems and Treatment Equipment

(1) Differing from Article 11, this article applies for systems and treatment equipment.

(2) Every natural or legal person who assembles products which bear the CE symbol, with the intention of putting them into use in the form of a system or as treatment equipment corresponding to their specified purpose and within their intended defined application, must provide a statement of content that

a) in mutual agreement, they have tested the products in accordance with the manufacturer's instructions and have performed the work steps in accordance with these instructions;

b) they have packaged the system or treatment equipment and have provided specific user instructions, including detailed manufacturer instructions;

c) The entire procedure was internally monitored and checked in an appropriate manner.

If the conditions as stated in Paragraph 2 have not been met, as would be the case when the system or the treatment equipment includes products which do not bear the CE symbol, or when the selected combination of products no longer corresponds to its original intended purpose, the system or treatment equipment shall be considered a separate product and, as such, is subject to the detailed specifications of Article 11.

The operator is responsible for maintenance of and compliance with national differences in EC countries!

Placement of Model Labels

Labeling

	HANS PAUSCH Röntgengerätebau D-91065 Erlangen Graf-Zeppelin-Str. 1
Type	<input type="text"/>
Fabr. Nr.	<input type="text"/>
Datum	<input type="text"/>
Spanng.	<input type="text"/> Volt
Frequenz	<input type="text"/> Hertz
Strom	<input type="text"/> Ampère
Made in Germany	01 25 89

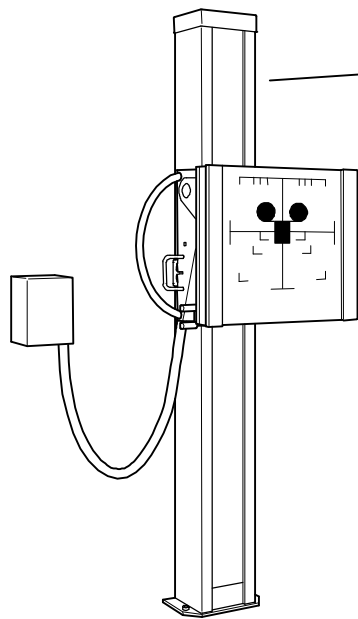

We reserve the right to make changes resulting from continuing technical developments.

TV/Ru