

CE according MDD

Contents

	Page
1. <i>Technical Data</i>	
1.1 General Safety Notes	3
1.2 Weight of Components	3
1.3 Dimensions of Components	3
1.4 Packing Details	3
1.4.1 During regular work	3
1.4.2 During transport	3
1.5 Component Designation	4
1.6 Dimensional Drawings	5
1.6.1 Dimensional Drawings/Floor Mounting	6
1.7 Routing of H.V. and Collimator Cables	7
1.8 Mains Connection Data	7
1.9 Special Tools Required	7
1.10 Measuring Equipment Required	7
1.11 Schematics	8
1.12 Wiring Diagram	9
1.11.1 Schematics GE	10
1.12.1 Wiring Diagram GE	11
1.12.2 Low Voltage Supply/Schematics	12
1.13 Physical Location of Electrical Components	13
1.14 Component Designation on Schematics	14
2. <i>Pre-installation and Installation</i>	
2.1 Pre-installation	15
2.1.1 Installation	15
2.2 Unpacking	15
2.3 Mounting Floor Guide Rails	15
2.4 Moving in Column with Carriage	16
2.5 Mounting Tube Support Arm	16
2.6 Inserting Weight Plates	17
2.7 Preassembly of Collimator and X-Ray Tube	18
2.8 Mounting Collimator and X-Ray Tube	20
2.9. Counterbalancing	22
3. <i>Adjustments</i>	
3.1 Tube Stand	22
3.2 Tube Support Arm	23
3.3 Tube Rotation Axis	23
3.4 40" SID Switch vertical	24
3.5 40" and 72" Switches horizontal	24
4. <i>Technical Maintenance</i>	
4.1 Mechanical and Electrical Check	25
4.2 Functional Check	30
4.3 Spare Parts	31
4.4 Spare Parts List	32
4.5 Name Plate Location	37
4.6 Maintenance Certificate	38

1. Technical Data

1.1 General Safety Notes

The equipment may only be used in rooms which comply with the relevant legislation and recommendations concerning electrical safety in rooms used for medical purposes, e. g. VDE Standard 0107 and/or IEC/SC 62 A concerning provision of an additional protective ground terminal for equipotential connection.

During installation it is important that all protective ground wire connections provided by the manufacturer are properly made before the equipment is started up.

The protective ground wires between the individual system, the components and the power supply are connected as shown in the wiring diagram.

Regulations of professional associations concerning safety and accident prevention must be observed. No work may be performed on parts carrying a voltage higher than 42 V.

The prohibition does not apply for measuring and adjustment procedures. But special care should be taken!

If functional checks during installation require power, please ensure that power is shut down immediately after completion of checks.

1.2 Weight of Components

floor rails complete	40 kg
column, column carriage, vertical carriage and counterweight carriage	76 kg
tube support arm	12 kg
control arm	3 kg
counterweight	55 kg
total weight incl. tube and collimator	c.225 kg

1.3 Dimensions of Components (mm)

floor rails complete	3012 x 145 x 72 mm
tube support arm	650 x 140 x 100 mm
column, column carriage, vertical carriage and counterweight carriage	2300 x 500 x 320 mm

1.4 Packing Details

1 box	3200 x 600 x 520 mm
gross weight:	c. 267 kg net
weight:	c 186 kg

1.4.1 During regular work

Temperature:	-25 to 70
Humidity:	5% to 95%
Air pressure:	700 hPa to 1100 hPa

1.4.2 During transport

Temperature:	10 to 40
Humidity:	20% to 80%
Air pressure:	700 hPa to 1100hPa

1.5 Component Designation

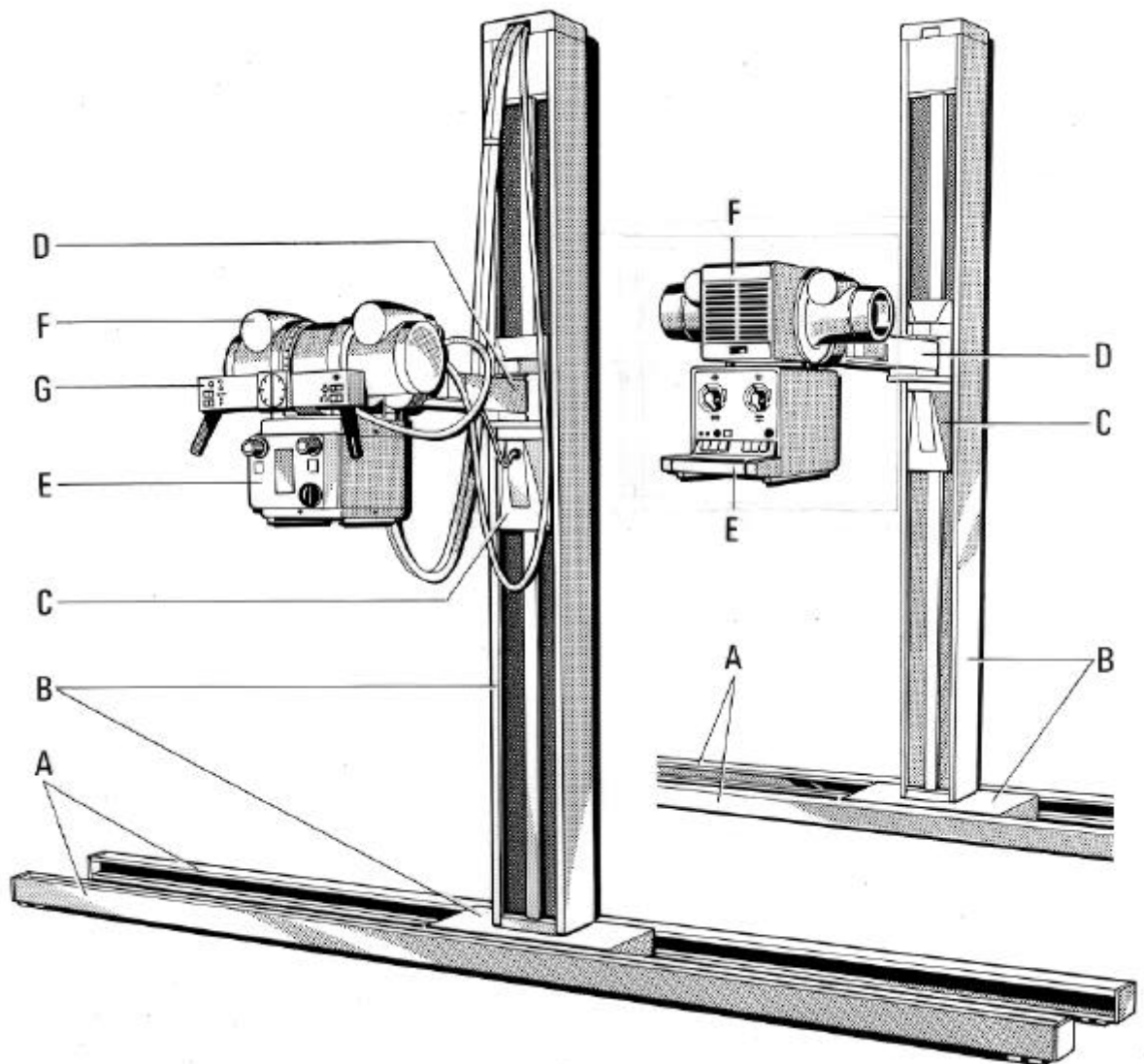

- A floor rails
- B column and column carriage
- C vertical carriage
- D rotational tube support arm
- E collimator
- F X-ray tube
- G control arm

1.6 Dimensional Drawing

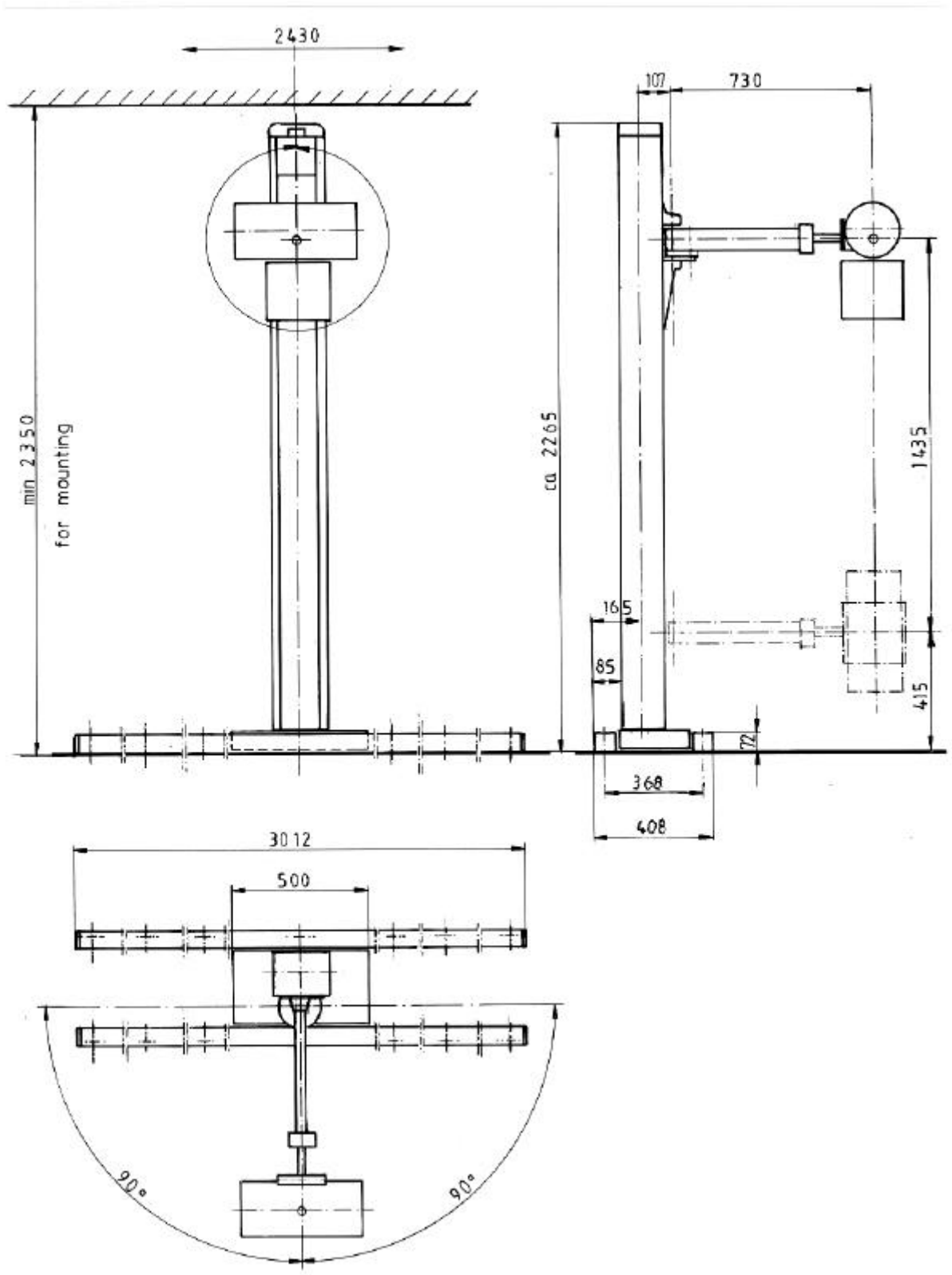

1.6.1 Dimensional Drawing/Floor Mounting

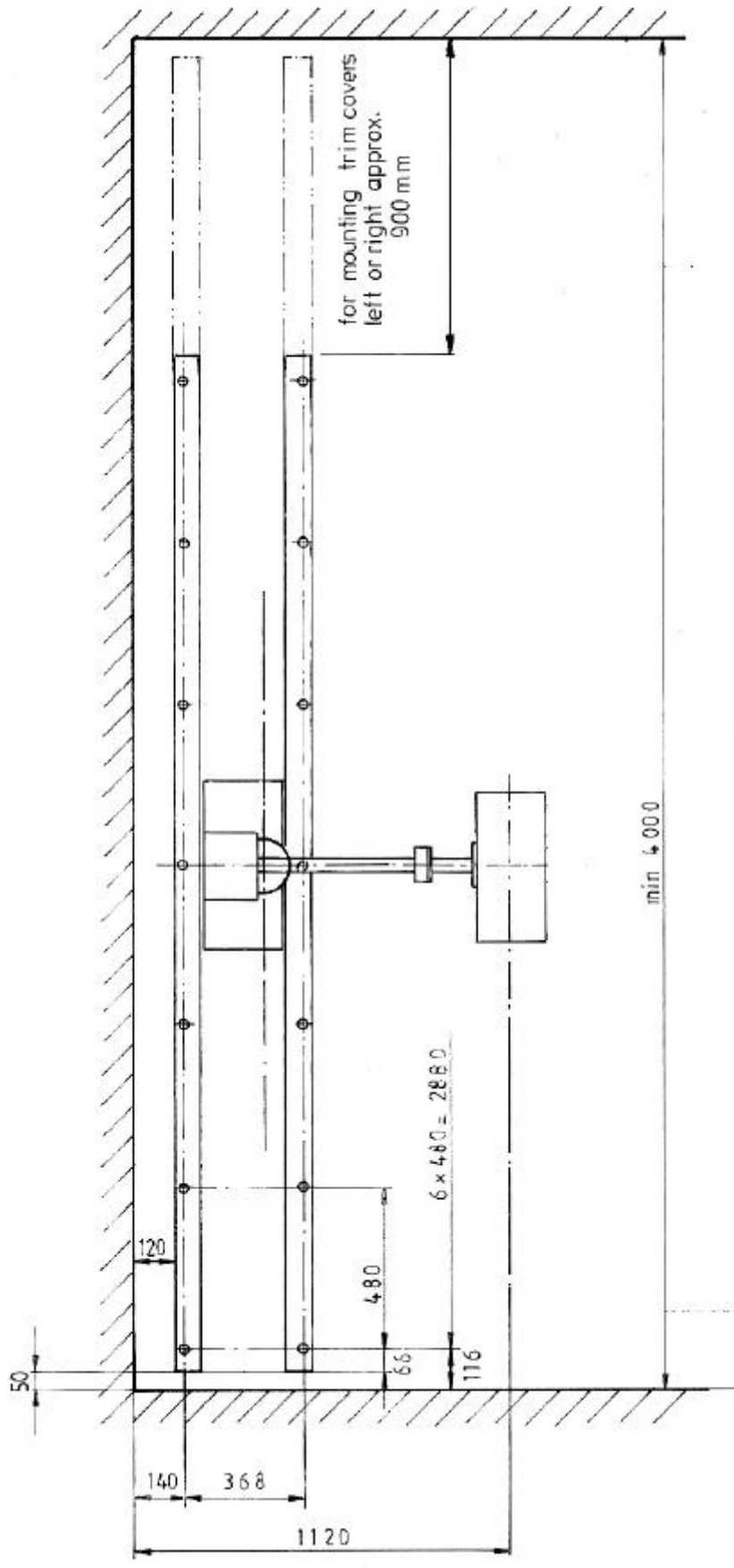

1.7 Routing of H.V. and Collimator Cables

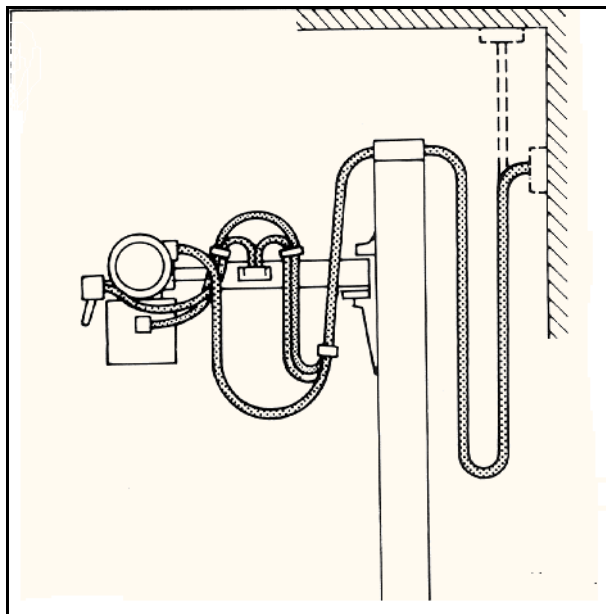

Fig. 1

X-ray tube:

Flange plate - mounting according to DIN 6836, Form C.

H.V. cable outlets 90 or 270 tangential or radial, preferably 90 .

HV cables:

Cable length from middle of X-ray tube to middle of column top approx. 2500 mm.

Cable length from middle of column top to wall approx. 2900 mm

(when cable outlet in wall is located on level of column top and middle of unit)

Refer to Fig. 1.

Travel distance of stand

1215 mm.

Collimator cable:

Cable length from collimator to middle of column top approx. 2700 mm.

1.8 Mains Connection Data

24 Volt DC

1,5 Ampere

1.9 Special Tools Required

Torque wrench

50 Nm (5mkp); 50 (lbf/in)

Masonry drill

12 mm; (.472 ") diameter

1.10 Measuring Equipment Required

Machinist's water level

1.12.1 Wiring Diagram GE

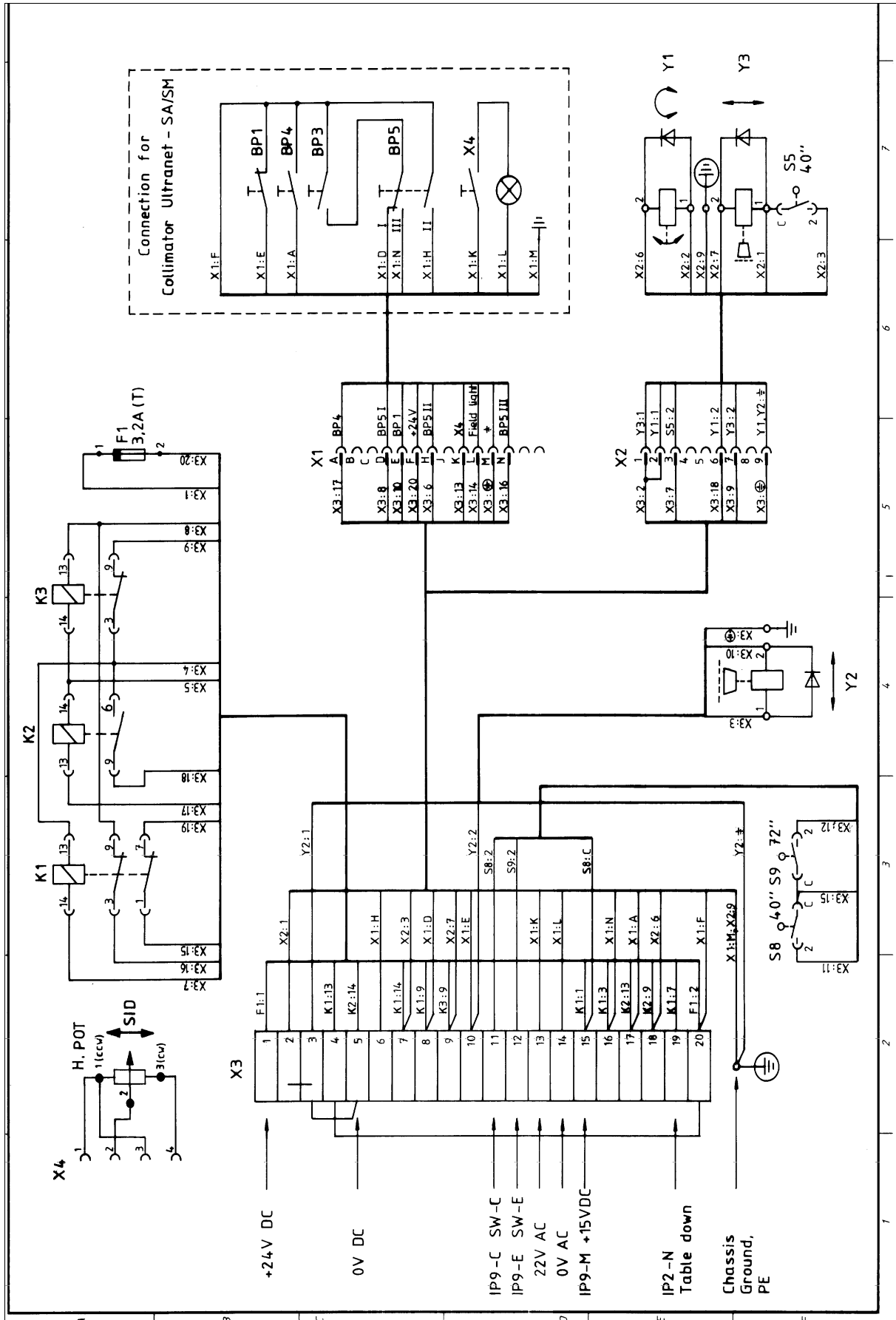

1.13 Physical Location of Electrical Components

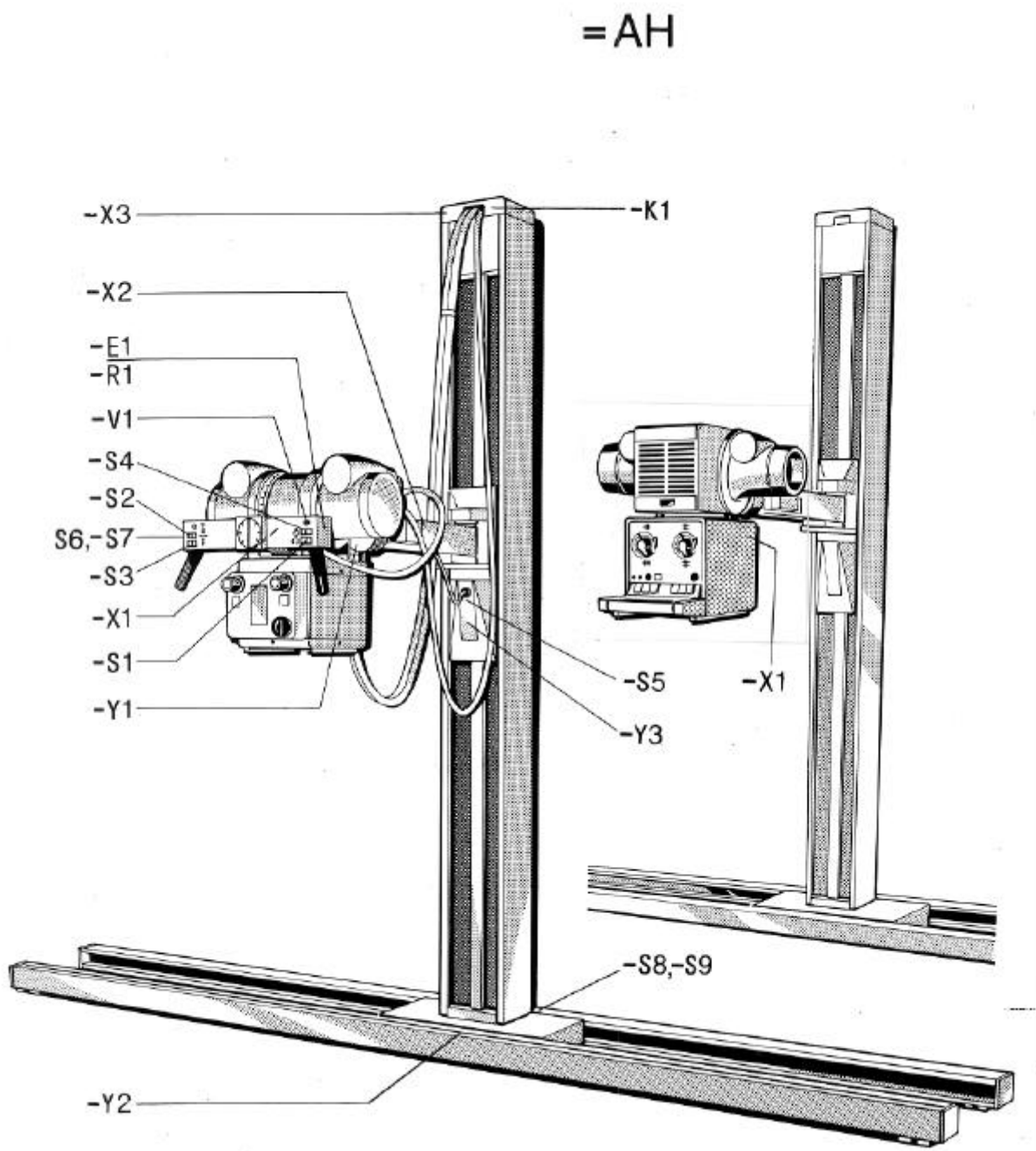

1.14 Component Designation on Schematics

Component No./ Component Designation

=AH -S1	switch rotation lock	
-S2	switch horizontal lock	
-S3	switch vertical lock	
-S4	switch pilot lamp	
-S5	40" SID switch	* *
-S6	+10 Mercury switch	*
-S7	-10 Mercury switch	*
-S8	40" switch horizontal	* *
-S9	72" switch horizontal	* *
-Y1	rotation lock	
-Y2	horizontal lock	
-Y3	vertical lock	
-X1	plug connection/control handle	
-X2	plug connection/tube support arm	
-X3	terminal strip/column top	
-X4	plug connection/ SID	
-K1	40" SID relay	* *
-R1	resistor	*
-V1	LED green	*
-E1	bulb	

* customer's request

* * with some versions

2. Pre-installation and Installation

2.1 Pre-installation

Note: The anchoring kit composed of 14 bolts (for 8mm diameter screws), screws and washers have to be provided by the purchaser of the equipment.

Note: Floor horizontality 0,5% (5 for 1000).

Drill mounting holes according to dimensional drawing 1.6.1, page 6. Drilling diameter 12 mm (.472"). Make sure to be within the required hole distance to ensure proper fit of the unit. The fastening points must be capable of holding 2400 N strength.

Example: Liebig-safety bolt S12/65 N in concrete type DIN 1045.

2.1.1 Installation

Remove vinyl or carpet floor covering around the mounting points of the rails by approx. 110 x 70 mm (size of shims). Lay shims (supplied with installation material) of the same thickness as the original floor covering onto the mounting points.

2.2 Unpacking

When unpacking, check the unit on completeness. Ensure that the unit is free from transportation damage.

2.3 Adjusting Floor Rails

Remove the covers (Fig. 2/item 1) on the side of the floor rails and remove trim covers (item 2). Place floor rails over prepared mounting holes.

Note: guide rail with brakestrip (Fig. 2/item 3) and end stops (item 4) is to be placed to the front.

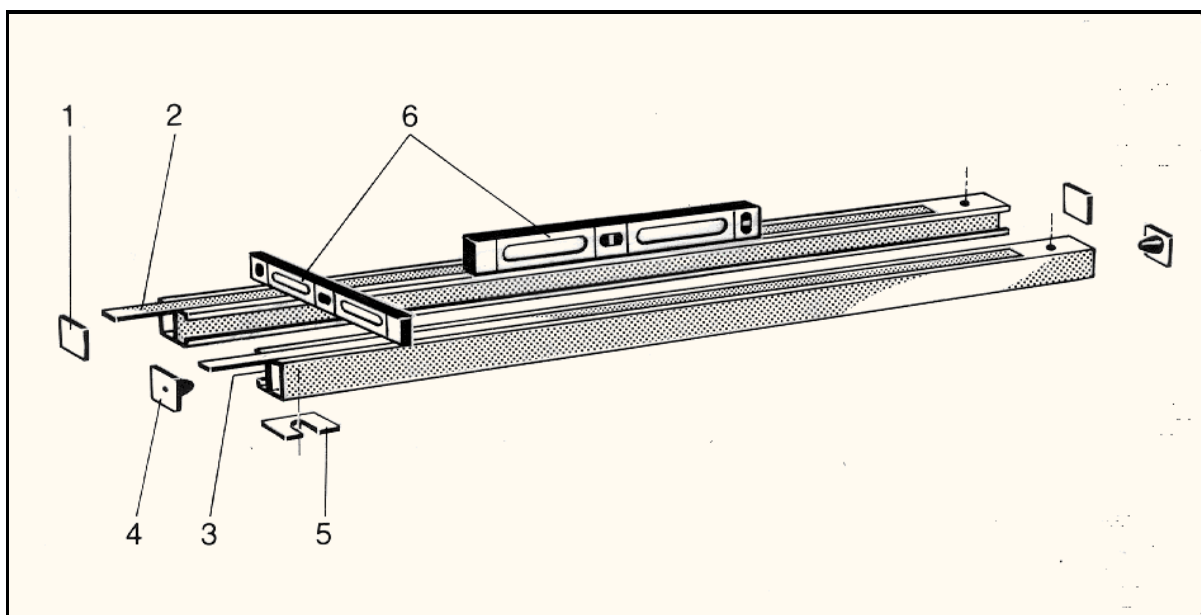

Fig. 2

With a water level (Fig. 2/item 6) the highest spot of one floor rail has to be determined by the help of shims (Fig. 2/ item 5) (supplied with installation material). Arrange heavy duty bolts acc. to Fig. 3, insert through floor rail and tighten screws slightly.

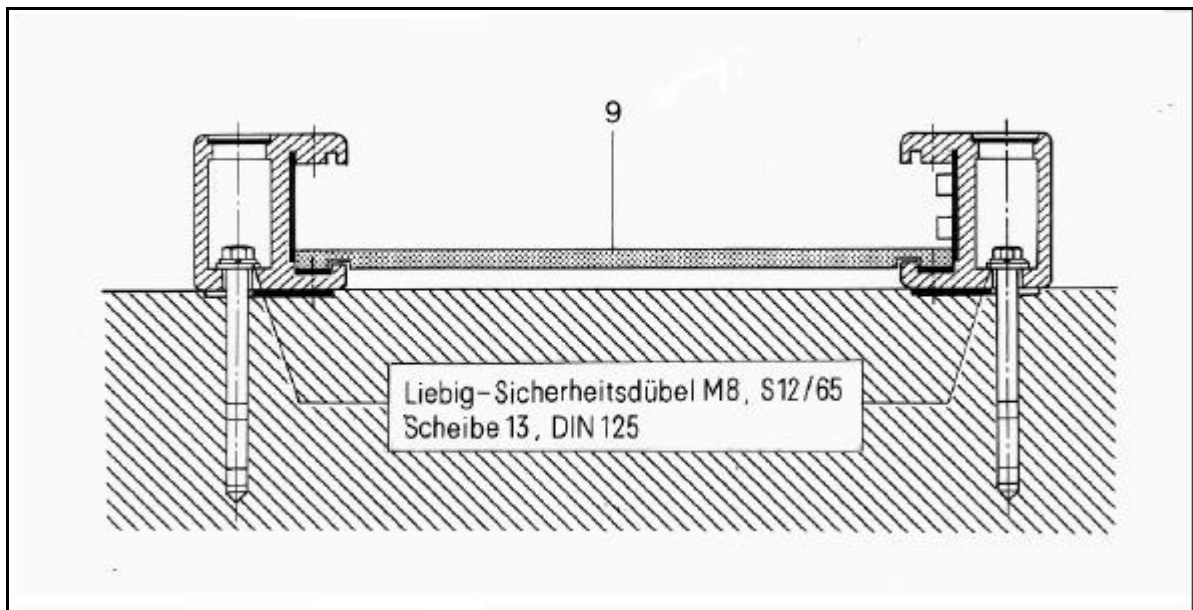

Fig. 3

If necessary level and shim the second floor rail to the same level surface as the first rail is (Fig. 2/item 5). Check with water level (Fig. 2/item 6) and adjust distance of rails with distance gauge (Fig. 3/item 9) (supplied with installation material). Finally tighten all 14 mounting bolts with torque wrench 50 Nm. Once again check adjustment of the floor rails. Insert each one shim into the two floor rails (Fig. 2/item 2).

2.4 Moving in Column with Carriage

To move along the column with carriage use a wooden board of about 6mm (.236") thickness for bearing protection. Place the wooden board right next to the head or foot end side of the floor rails (depending on which side the column is to be brought in). Bring the column in upright position and put it on the wooden board. Carefully move the column into the rails keeping attention on the horizontal brake and the SID switch to prevent them from being damaged. Then install cover on back rail (Fig. 2/item 1) and cover on front rail (Fig. 2/item 4).

2.5 Mounting Tube Support Arm

Remove the bolt from the tube support arm (Fig.4/item 10). Put the set screw (item 11) with steel ball inserted (item 12) into the vertical carriage, slide in disk (item 13), introduce bolt (item 10). Insert bushing (item 14), adjust in center of drilling and screw up. Adjust function of detent by tightening screw (Fig. 4/item 11). Turning the screw (to the right) increases pressure of the cup springs and detent uncatches harder.

Note: The force required to overcome the detents is 120 N at the control handle.

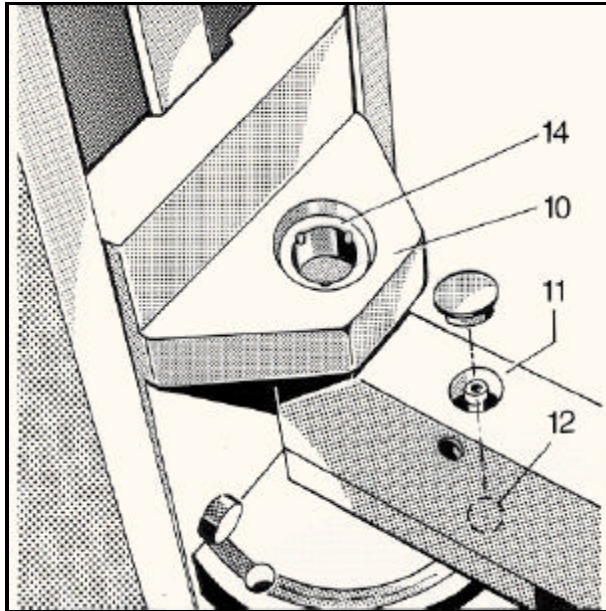

Fig. 4

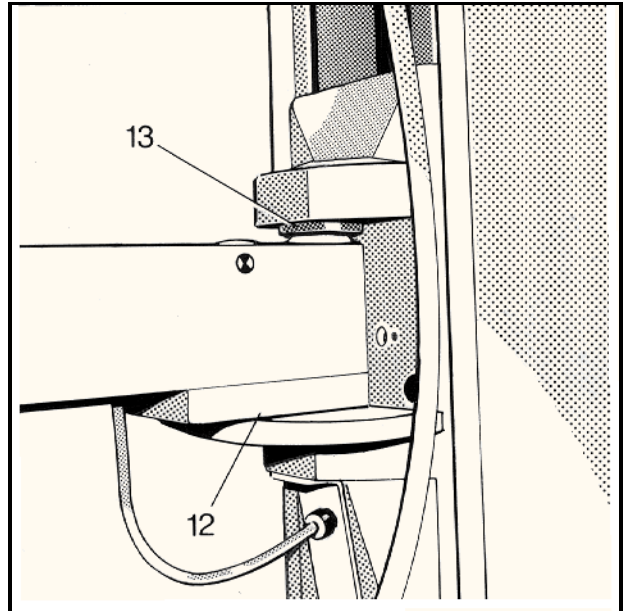

Fig. 5

2.6 Inserting Counterweights

Remove trim cover from the back of the column (Fig. 6/item 53).

The counterweight plate having 2 holes (item 55) is to be inserted first by help of a solenoid (item 57) (supplied with installation material). Continue with other weight plates (item 58) until they become visible in the counterweight carriage. The remaining weight plates can be inserted without using the solenoid. The clamping plate (item 56) is the final one to be inserted.

Attention: Only tube collimator combinations with a max. weight of 45 kg can be installed.

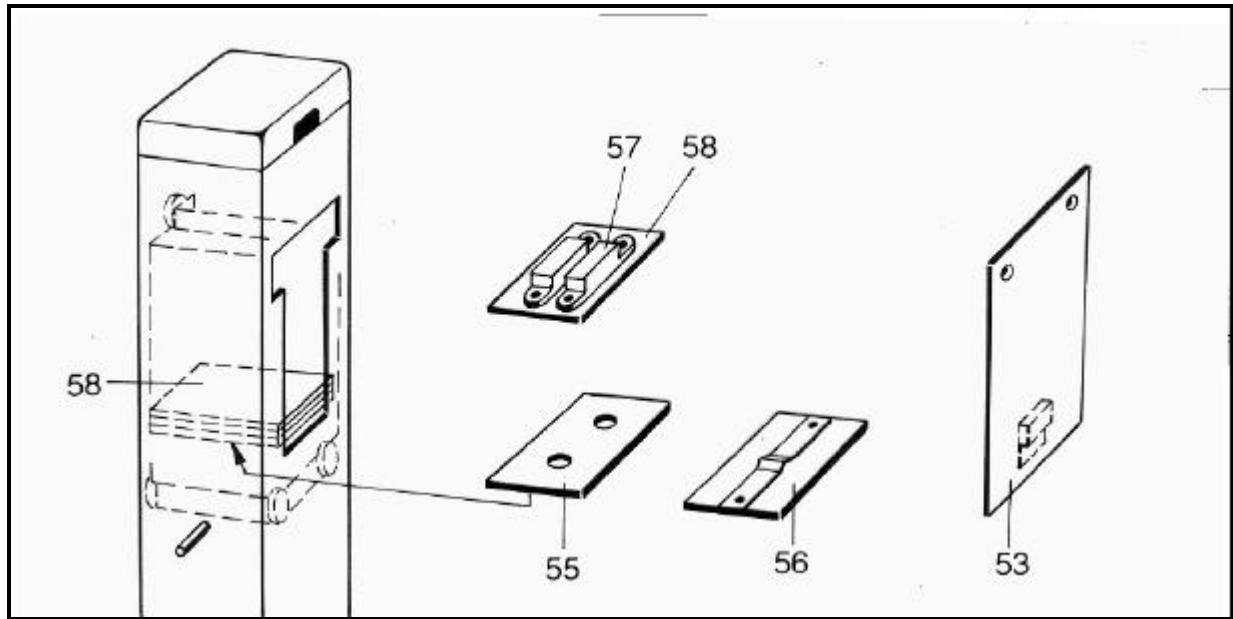

Fig. 6

2.7 Preassembly of Collimator and X-Ray Tube

Polyphos Single Tank:

Preassemble tube and collimator according to the Siemens instructions.

Fasten control handle (Fig. 7/item 15) to the "Polyphos Single Tank" by means of pacer bushings (item 17) and screws (item 16).

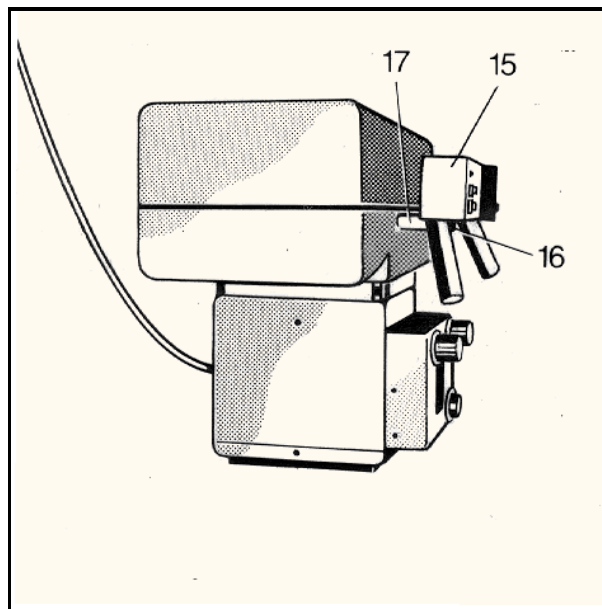

Fig. 7

Siemens X-ray tube:

Remove intermediate ring (Fig. 8/item 20) from flange (item 18) and mount support arm (item 19). Fasten control handle (Fig. 9/item 15) to support arm (item 19).

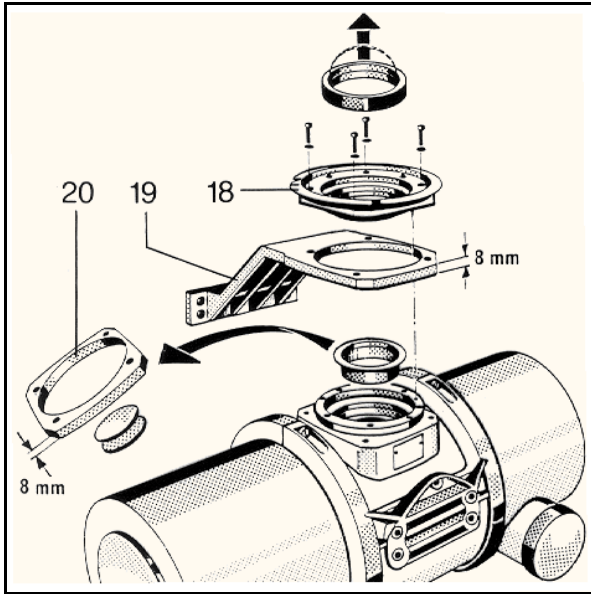

Fig. 8

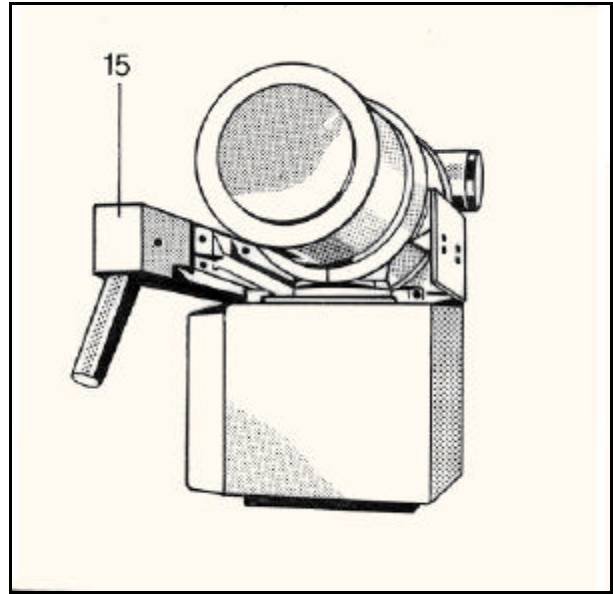

Fig. 9

Philips Rotalix:

Mount the Z-shaped bracket (Fig. 10/item 23) to flange. Fasten control handle to Z-shaped bracket (item 21).

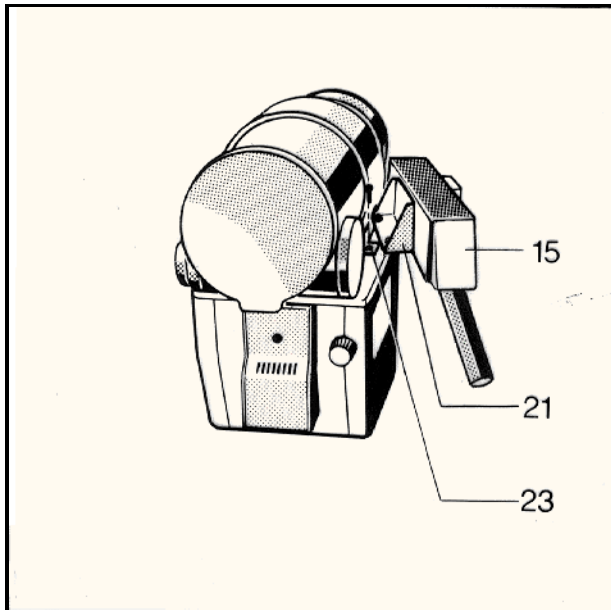

Fig. 10

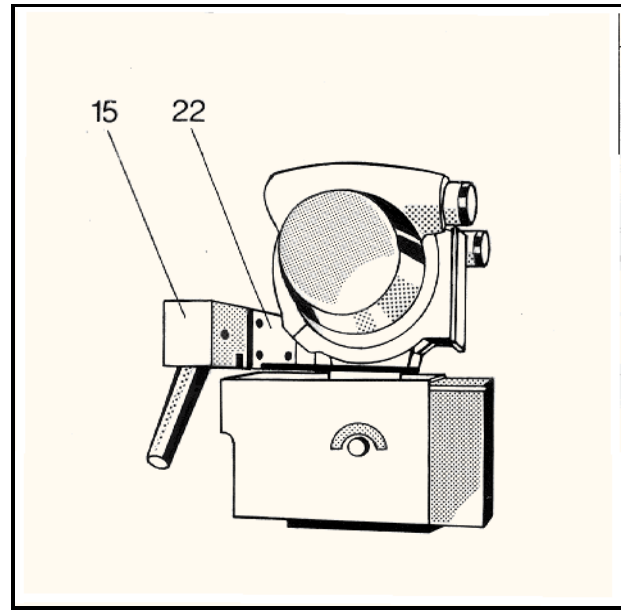

Fig. 11

Comet tube with Comet collimator:

US tube with Machlett collimator:

Mount control handle (Fig. 11/item 15) with bracket (item 22) between X-ray tube and collimator.

Other tube and collimator models / flange diameter 136:

Mount control handle (Fig. 12/item 15) with support arm (item 23) and flange (item 24) between tube and collimator.

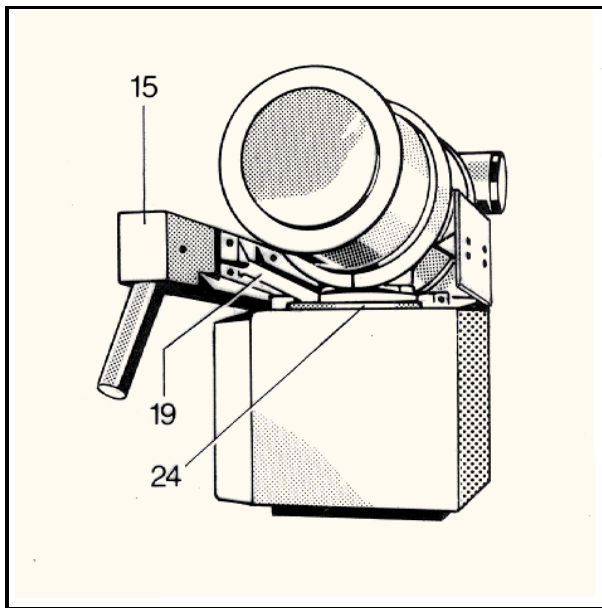

Fig. 12

2.8 Mounting Collimator and X-Ray Tube

Note: Move the center of gravity of the tube-collimator assembly into the tube support arm by displacing the unit vertically on the compensating plate (Fig. 13/item 25). Even though the compensating plate (item 25) is not needed, it must be mounted as a spacer plate.

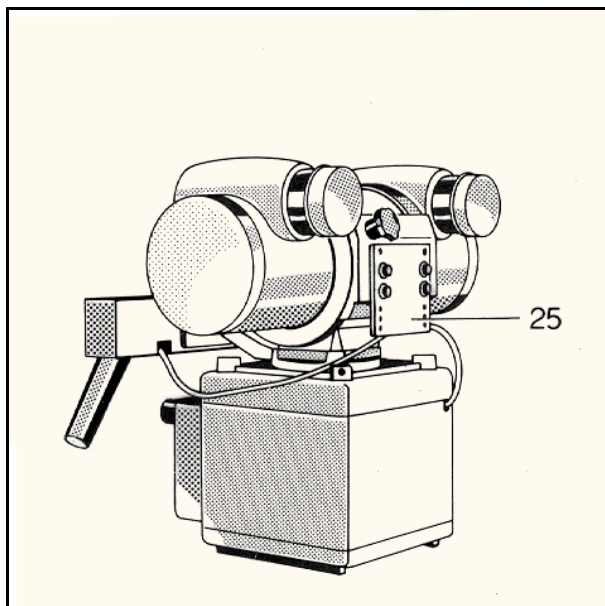

Fig. 13

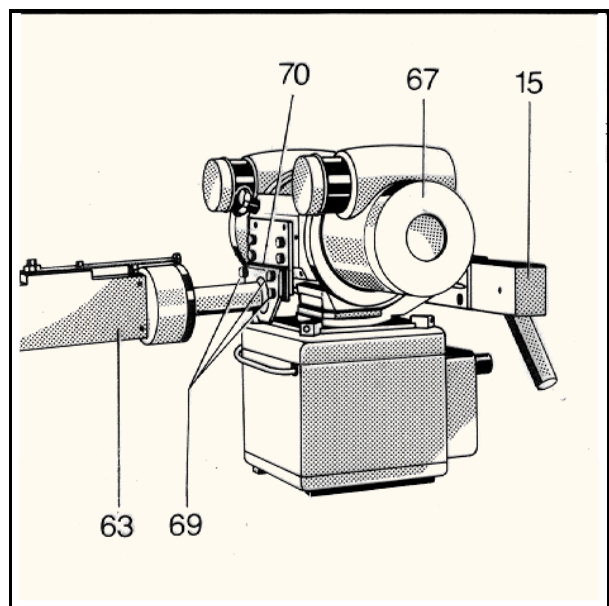

Fig. 14

Put preassembled tube-collimator assembly (Fig. 14/item 67) down on level of tube support arm and mount to support arm (item 68) by means of screws (item 69) after inserting adjusting plate (item 70). Connect cable with plug in control handle (item 15).-

GE tube MX-75:

Dismount X-ray tube from GE trunnions (Fig. 15/item 60). Mount trunnions to tube support arm (item 63) with screws (item 61).

Note: The center of gravity of the tube-collimator assembly should lay in the rotational axis of the tube support arm. If necessary, the distance focus-column centre may be increased by inserting shims (item 64). Mount tube to trunnions and tube support arm and connect cable to plug of collimator.

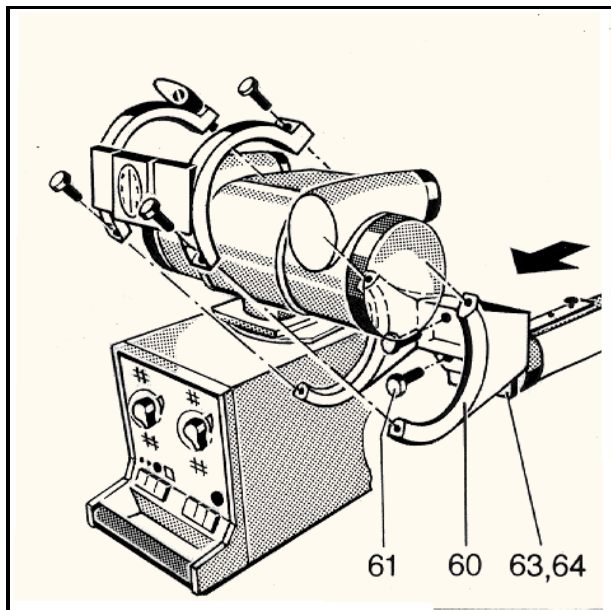

Fig. 15

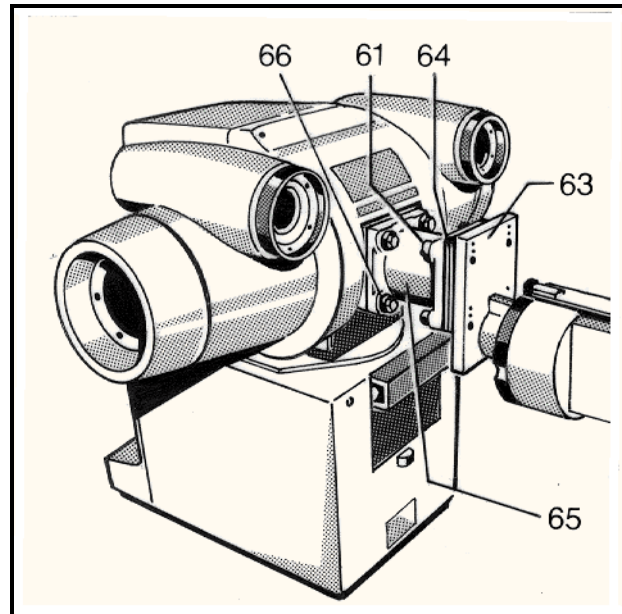

Fig. 16

GE tube MX-100:

Fasten spacer (Fig. 16/item 65) to X-ray tube with screws (item 66) and mount to tube support arm (item 63).

Note: The center of gravity of the tube-collimator assembly should lay in the rotational axis of the tube support arm. If necessary, the distance focus-column centre may be increased by inserting shims (item 64). Mount tube to trunnions and connect cable with plug of collimator.

2.9 Counterbalancing

Take round steel (Fig. 6/item 54) carefully out of column. Counterbalance weight difference by weight plates (item 58) and cover drillings with caps (supplied with installation material).

3. Adjustments

3.1 Tube Stand

Check the upright position of the column (Fig. 19/item 68) with water level (item 71). If it is necessary to adjust the column position, remove cover plate (Fig. 18/items 26 and 26a), turn outer pulleys (items 72, 72a and 74, 74a) by adjusting eccentric axis so that they don't touch the running surface. The column can now be adjusted in its upright position by turning the inner eccentrics (items 73, 73a and 75, 75a). When the column is in the proper position, turn back the outer pulleys so that they touch the running surface. Move the column over entire travel range and check for smooth and easy running.

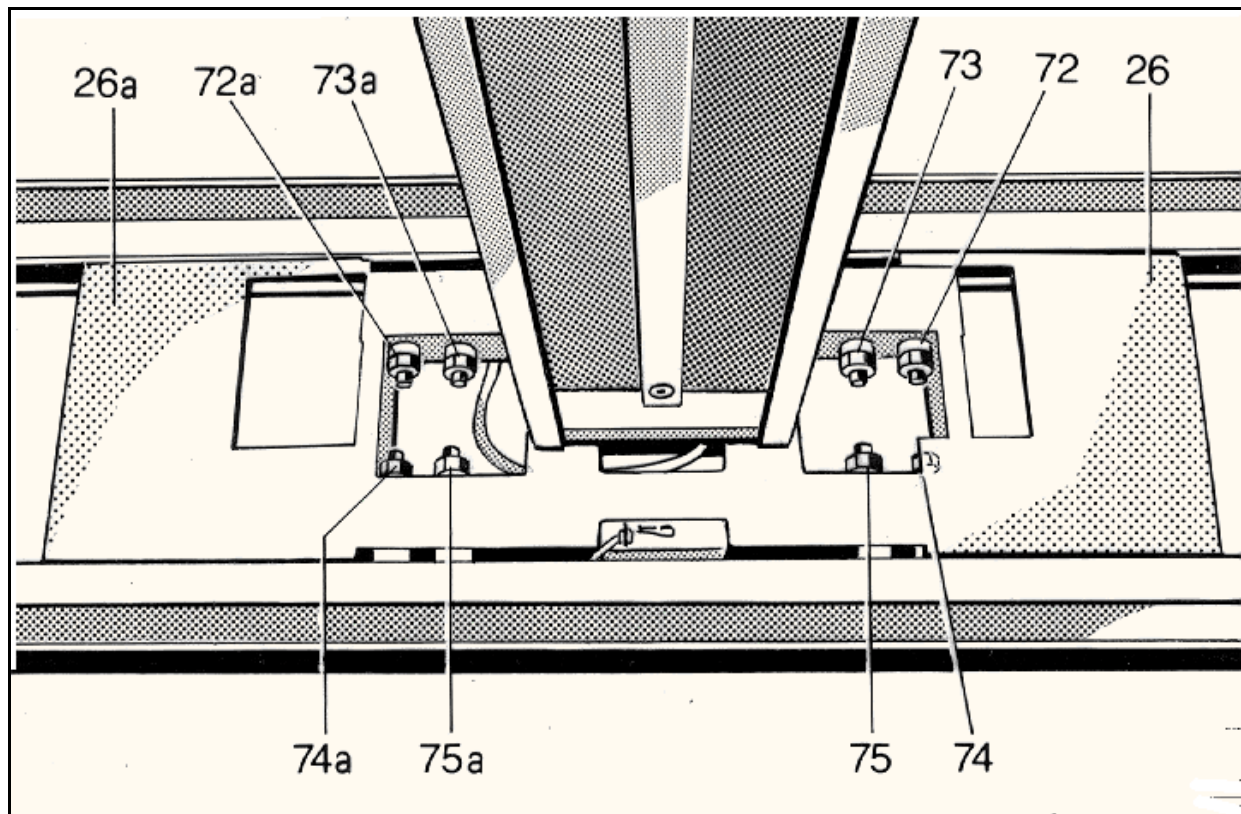

Fig. 18

3.2 Tube Support Arm

Check tube support arm (Fig. 20/item 63) with water level (Fig. 20/item 71). If there is a difference, remove plastic cap (item 27) and adjust set bushing (item 28) by adjusting threaded pins. This check resp. adjustment has also to be done in the 90° tilt positions.

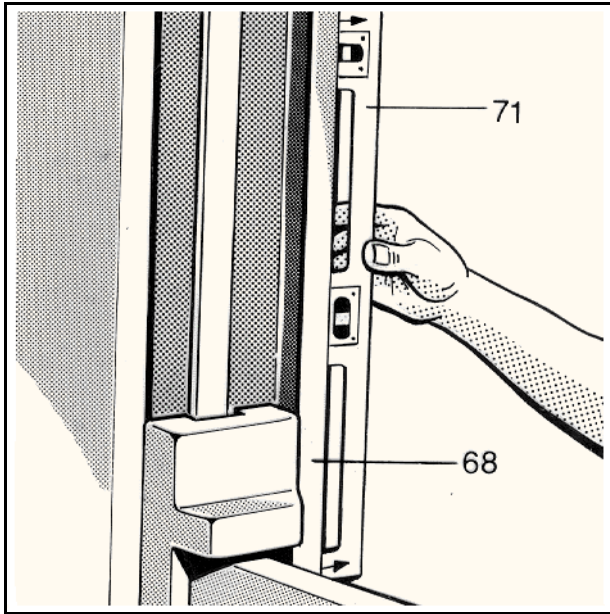

Fig. 19

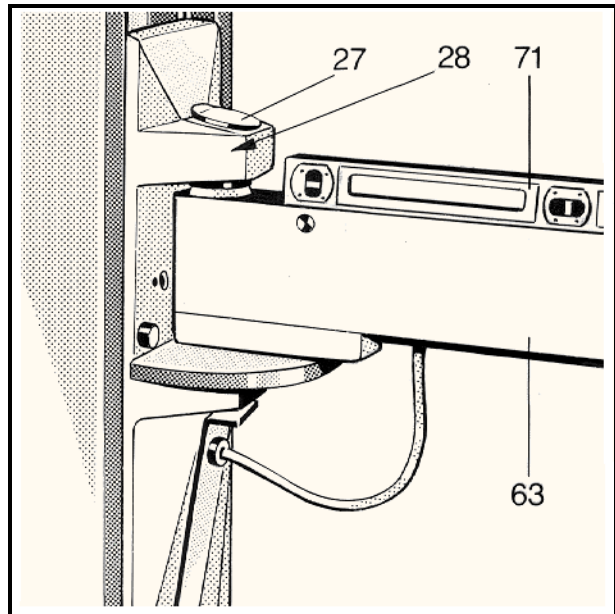

Fig. 20

3.3 Tube-Rotation Axis

Check upright position of flange plate with water level (Fig. 21/item 31). If there is a difference, turn in both socket head screws (Fig. 22/item 29). Adjust upright position of flange plate (Fig. 21/item 31) with water level in place by turning both screws (Fig. 22/item 30). Lock again with socket head screws (Fig./item 29).

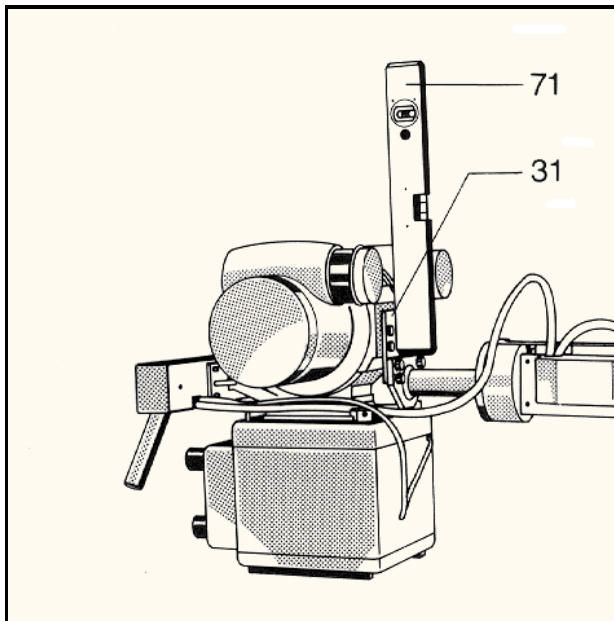

Fig. 21

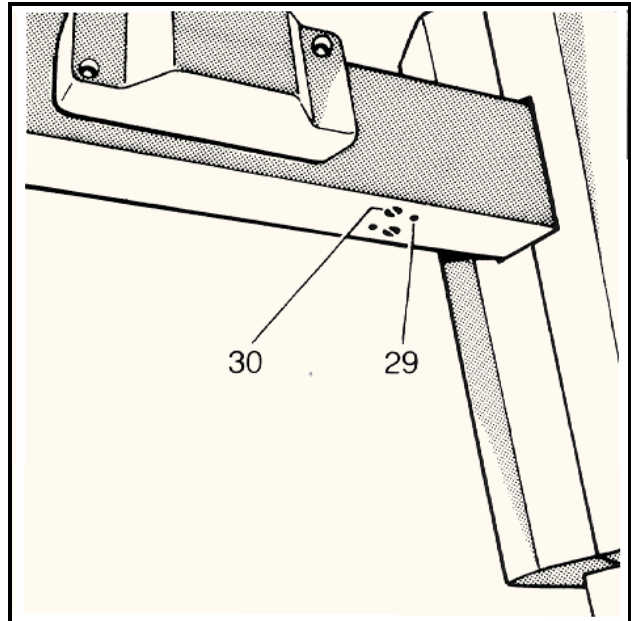

Fig. 22

3.4 40" SID Switch

Switch: Remove cover cap (Fig. 23/item 33) from vertical carriage. Adjust 40" switch -S5 in vertical carriage after loosening the two screws within range of slotted holes

FFD: Adjust cam (Fig. 24/item 34) on column after loosening screws. Range of adjustment approx. 85 mm.

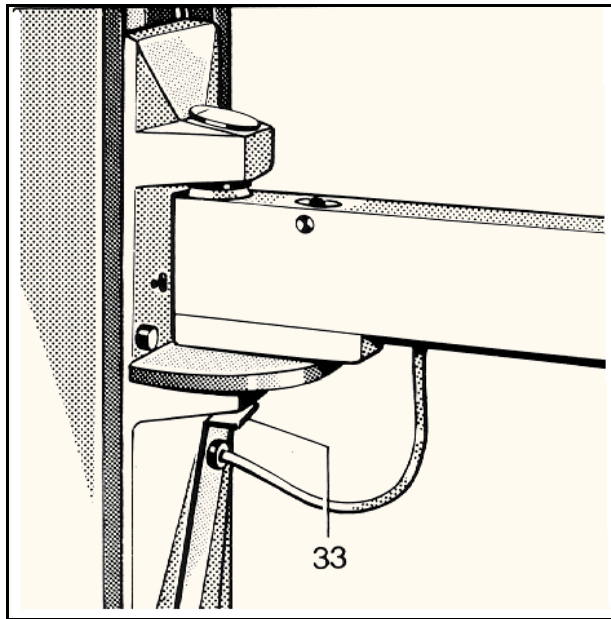

Fig. 23

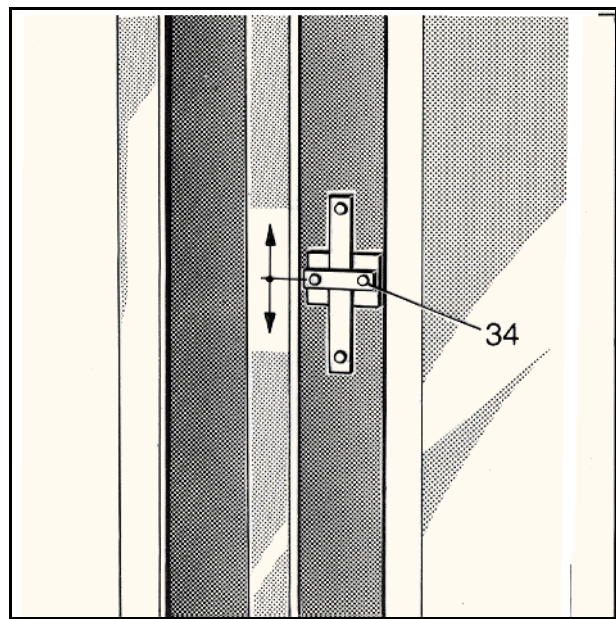

Fig. 24

3.5 40" and 72" Switches horizontal

Switches: Remove cover cap (Fig. 18/item 26a) and adjust switches -S8, -S9 (Fig. 25/item 35) within range of slotted holes.

FFD: Adjust switching rod on rear floor profile (Fig. 28/item 36) after loosening the two set screws.

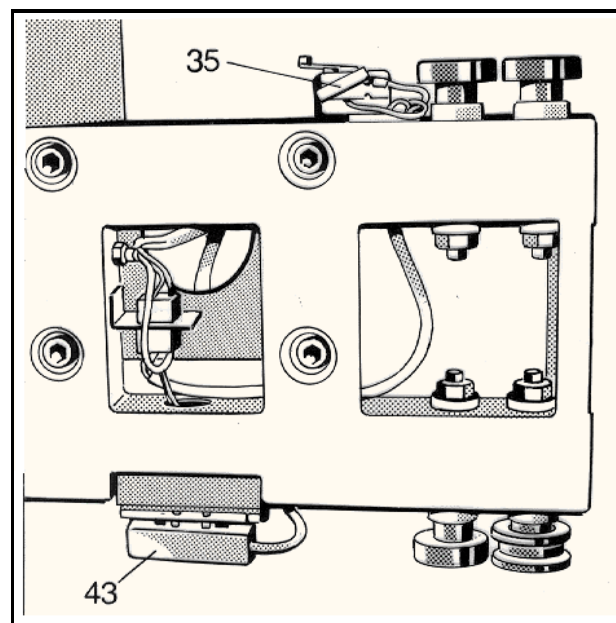

Fig. 25

4. Technical Maintenance

4.1. Mechanical and Electrical Check

Note: The maintenance tasks and functional checks described hereafter have to be performed in 12-month intervals. When power is needed for functional checking always turn off power after check completion. Failed parts may only be replaced with original parts as listed in the spare parts list.

Use only non-acid grease for maintenance. Do not grease or oil sealed ball bearings.

Preparation:

- * Turn off power.
- * Remove lateral covers (Fig. 28/ items 40 and 40a) from floor rails, push out trim covers (Fig. 28/ items 41 and 41a) and lay them down.
- * Remove cap (Fig. 18/items 26 and 26a).

Floor rails:

- * Check all floor mounting bolts (Fig. 28/item 42) for proper fit and tighten if necessary. Torque 50 Nm.
- * Clean all running surfaces and check upon damage.
- * Check bumper stops for damage.

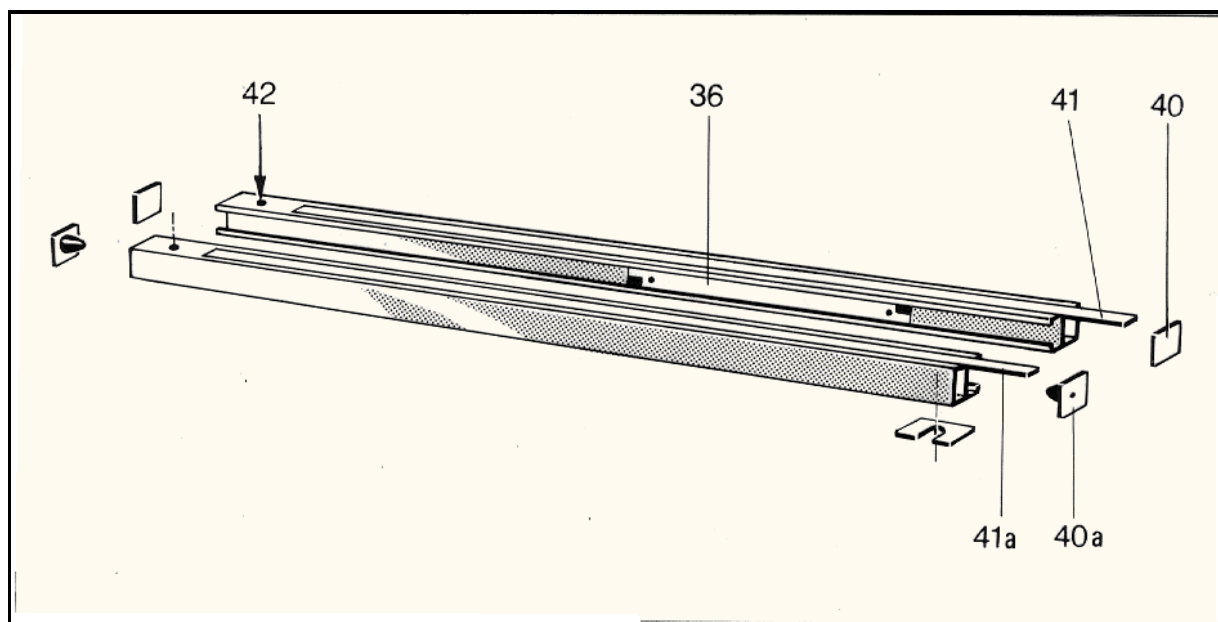

Fig. 28

Column carriage:

- * Check for easy movement over entire travel range. Running noise? If any, determine defective bearing. Replace if necessary.
- * Switch on unit, check function of brake (Fig. 29/item 43). Adjust if necessary. To do so, loosen lock nut, turn threaded pin accordingly and lock again.

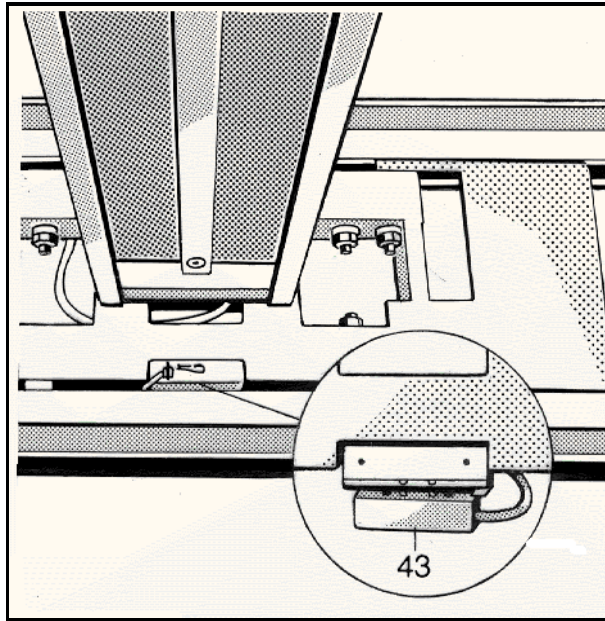

Fig. 29

Column and vertical carriage:

?

- * Clean running surface. Slightly lubricate.
- * Move vertical carriage over entire travel range. Easy movement
- Running noise ? Determine defective bearing and replace if necessary - reference "General Notes B" on page 26.
- * Clean counterweights wire rope (do not use fat solvents) and check for damage. Slightly lubricate.
Attention: Upon slightest damage the cable has to be replaced immediately.

Wire rope PN. 0327 0440 has to be replaced at least every 3 years.

- * Visually check guide pulley.
- * Check function of brake - refer to "General Notes C" on page 26.

* Check function of vertical carriage brake (Fig. 32/item 47). Adjust if necessary. To do so remove cover (Fig. 31/item 45). Adjust brake at locked screw (Fig. 32/item 46). Install cover again.

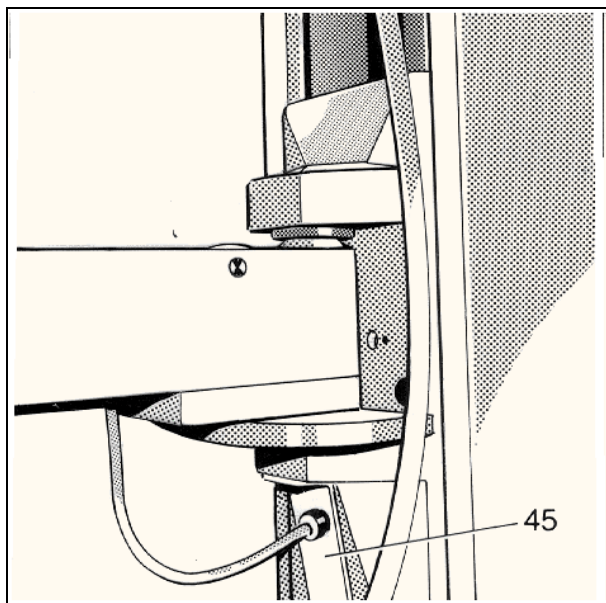

Fig. 31

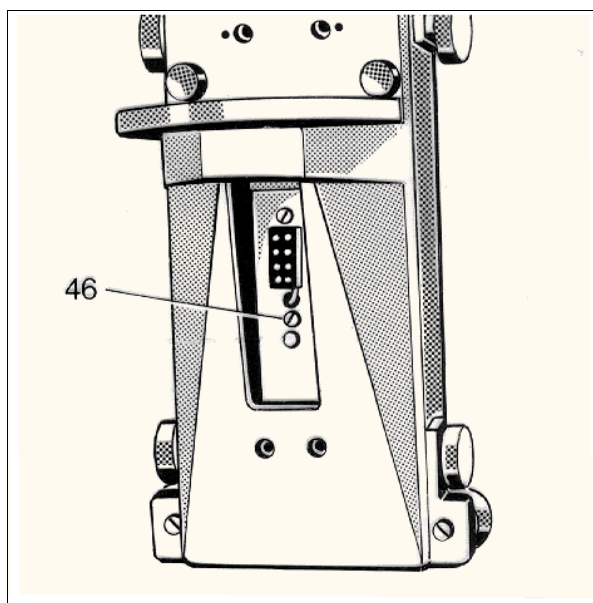

Fig. 32

Vertical carriage:

* Check detent function of tube support arm at the control handle by tilting X-ray tube. The force required to overcome the detent should not exceed 12 N. If necessary adjust spring pressure by turning locked screw (Fig. 33/item 48). Slightly lubricate running surface of detent ball.

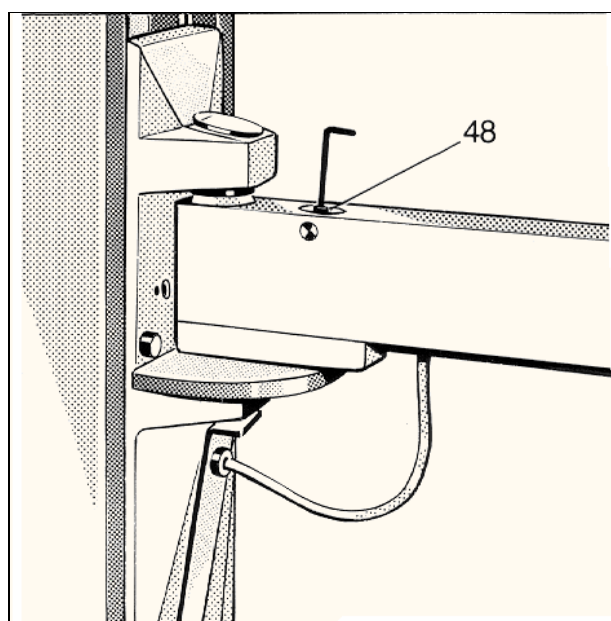

Fig. 33

General electrical checking:

- * Check all cables for damage. Replace defective cables.
- * Check strain relief and ground connections for proper fit.
- * All exposed dead metal or other conductive parts that are exposed to contact during any servicing operation shall be electrically connected to the equipment grounding terminal and must carry less than 0,1 Ohm resistance.
- * Reinstall all trim covers.
- * Clean unit.
- * Turn on power.

General notes:

screw.

A Check function of brakes "by feeling" and adjust if necessary. The gap between solenoid and braking surface has to be adjusted to 0,2 - 0,3 mm with the corresponding adjusting

caps

B To exchange a pulley of vertical carriage follow the instructions below: Drive weight box all up to the top. Remove plastic from lateral walls of stand. Introduce round steel (supplied with installation material)(Fig. 34/item 50).

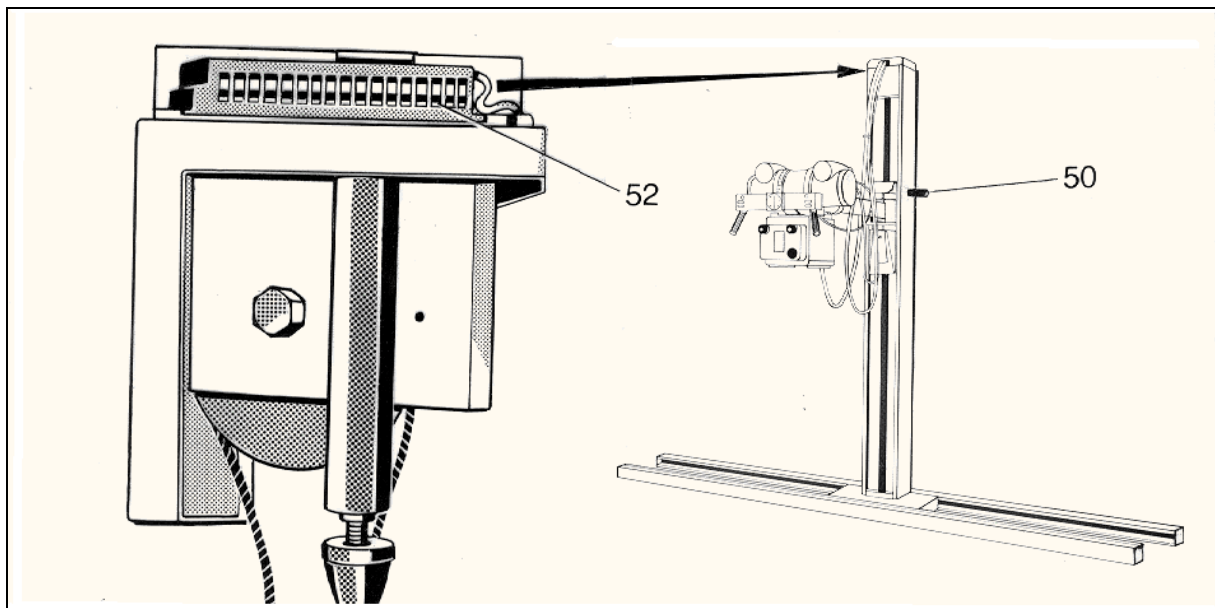

Fig. 34

Lower weight box until it stops at round steel (item 50). Dismount tube assembly from tube support arm. Remove cap from column top and disconnect leads from terminal strip (Fig.34/item 52). Lift vertical carriage by 400 mm. Take off screws of column top (Fig. 34/item 53) and remove top. Drive up vertical carriage and loosen cable from brake pivot. Now the vertical carriage can be pulled all the way out. Replace bearings (rollers). To drive in vertical carriage again, reinstall cable and pull upward until it stops to loosen brake for driving in. Mount head part with guide pulley again. Lift vertical carriage by a few cms and instantaneously loosen brake by pulling cable upward. Slowly lower carriage until it hangs at the cable. Clamp cable and install cap. Mount tube-collimator assembly to tube support arm. Remove round steel and install plastic cap.

- C** Check function of brake as follows:
lateral walls Drive weight box up to the top. Remove plastic caps from of stand. Introduce round steel (supplied with installation material)(Fig. 34/item 50). Drive weight box until it stops at round steel. Lift vertical carriage by a few cms. Release: Vertical carriage must hold by itself. Lift vertical carriage again and instantaneously loosen safety brake by pulling at rope. Then slowly lower vertical carriage until cable is tight.

4.2 Functional Check

Column carriage: Move column carriage over entire travel range.

- * Easy running movement ?
- * Running without noise ?
- * Accurate braking in any position ?
- * Accurate releasing of brake ?

Vertical carriage: Move vertical carriage over entire travel range.

- * Easy running movement ?
- * Running without noise ?
- * Accurate braking in any position ?
- * Accurate releasing of brake ?
- * Guide pulley running without noise ?
- * Cable moving without twisting ?

Tube support arm: Swivel tube support arm left and right its' 90 detents.

- * Easy running movement ?
- * Running without noise ?
- * Proper "Feel" indication of detent ?
- * Quiet motion while rotating ?

Control handle: Check LED indication by 40" vertical SID

- * LED flashing when vertical carriage is moved over the trip cam ?
- * LED going out when vertical carriage is leaving trip cam range ?
- * Proper angle indication ?

Tube rotation: Check tube over entire rotation range.

- * Easy running movement ?
- * Running without noise ?
- * Accurate braking in any position?
- * Accurate releasing of brake ?

4.3 Spare Parts

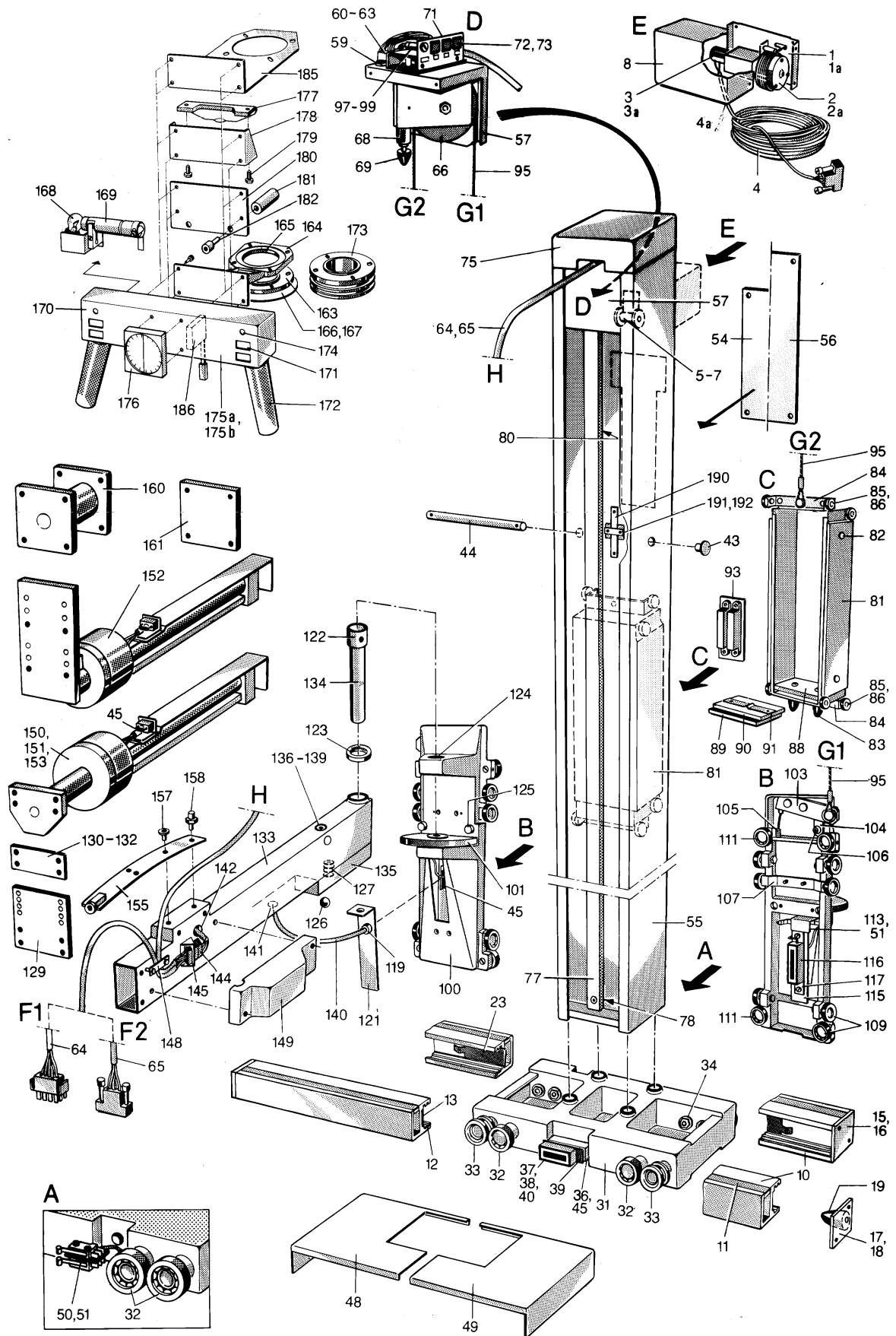

4.3.1 Spare Parts List

Part Names / Ordering Numbers

Failed spare parts may be replaced only with original parts as listed below. When ordering spare parts always indicate serial number of unit and complete number of part. The exchange of parts or elements may only be carried out by ourselves or by qualified personnel being authorized to do so. See also chapter: "Safety Notes".

Item	Designation	Order No.
1	Vertical SID assembly compl.	0327 0630
1a	Vertical SID assembly compl. GE	0327 0630b
2	SID drive only with Pot, Cable	0327 0638
2a	SID drive only with Pot, Cable GE	0327 0638b
3	Potentiometer 1 K	0006 0240a
3a	Potentiometer 5 K GE	0006 0240c
4	Cable	0327 0639
4a	Cable GE	0327 0629
5	Pulley	0327 0635
6	Bolt	0327 0633
7	Snap ring 8 DIN6799	2200 0041
8	Cap	0327 0632
9		
10	Floor guide rail	0327 0301
11	Cover	0327 0302
12	Wear strip	0327 0304
13	Brake surface	0327 0303
14		
15	Side cover left	0327 0308
16	Side cover right	0327 0309
17	Lid	0327 0310
18	Lid	0327 0311
19	Parabolic spring	0327 0399
20		
21		
22		
23	Switching rod	0327 0305
24		
25		
26		
27		
28		
29		
30		
31	Frame	0327 0320
32	Roller	0327 0334
33	Roller	0327 0335
34	Nut M12 DIN934	2100 0013
35		
36	Solenoid bracket	0327 0341
37	Solenoid	0006 0603

Item	Designation	Order No.
38	Bushing	0327 0343
39	Spring	0327 0342
40	Bushing	0327 0344
41		
42		
43	Cover cap	0008 0141b
44	Rod	0327 0410
45	Diode	0006 0179
46		
47		
48	Cover	0327 0345
49	Cover	0327 0349
50	Switch assembly	0327 0321
51	Switch	0006 0184
52		
53		
54	Cover	0327 0438
55	Column	0327 0350
56	Cover	0327 0357
57	Column top	0327 0380
58		
59	Cable clamp	0327 0370
60	Terminal strip	0006 0102
61	Clip	0006 0103
62	Terminal strip	0006 0112
63	Terminal strip guide	0327 0376
64	Cable	0327 0490
65a	Cable	0327 0491
65b	Cable Ultramet	0327 0494
66	Pulley assembly	0327 0374
67		
68	Stop	0327 0372
69	Parabolic spring	0005 0103b
70		
71	Relay bracket	0327 0389
72	Relay socket	0006 0287
73	HC relay	0006 0286b
74		
75	Top trim cover	0327 0385
76		
77	Strip	0327 0390
78	Bushing	0327 0393
79		
80	Cable	0327 0394
81	Counterweight	0327 0400
82	Delrin nipple	0327 0415
83	Parabolic spring	0005 0103b
84	Wheel mount	0327 0408
85	Roller	0327 0427
86	Bushing	0327 0428
87		
88	Plate	0327 0411
89	Weight plate	0327 0409
90	Nut plate	0327 0412

Item	Designation	Order No.
91	Spring	0327 0413
92		
93	Solenoid	0327 0425
94		
95	Wire rope 1928 mm	0327 0440
96		
97	Fuse holder	0006 0144
98	Fuse cap	0006 0152b
99	Fuse 3.2 A.T	0006 0308g
100	Vertical carriage	0327 0450
101	Detent plate	0327 0455
102		
103	Safety brake	0327 0420
104	Spacer	0327 0424
105	Spring	0005 0151j
106	Shoulder bushing	0327 0471
107	Roller bracket	0327 0470
108		
109	Roller with bolt	0327 0474
110		
111	Roller with eccentric bolt	0327 0472
112		
113	Switch support	0327 0466
114		
115	Solenoid bracket	0327 0431
116	Solenoid	0006 0603
117	Solenoid spring	0327 0462
118		
119	Bushing	0006 0345
120		
121	Cover	0327 0479
122	Adjustment ring	0327 0417
123	Disc	0327 0483
124	Lid	0327 0482
125	Bumper	0005 0164a
126	Ball 16 DIN5401	2900 0004
127	Belleville spring 20 DIN2093	2500 0005
128		
129	Compensating plate	0325 0329
130	Spacer for tube	0322 0242
131	Adjusting plate	0380 0335
132	Shim	0322 0811
133	Tube support arm assembly	0327 0130
134	Arbor	0327 0457
135	Ball holder	0327 0504
136	Shoulder bolt	0327 0505
137	Disc	0327 0506
138	Bolt	0327 0507
139	Plastic cap	0008 0141e
140	Cable	0327 0510
141	Strain relieve	0006 0345b
142	Bushing	0006 0107c
143		
144	Plug	0006 0211c

Item	Designation	Order No.
145	Plug bracket	0322 0302
146		
147		
148	Strain relieve	0322 0306
149	Cap	0322 0058
150	Tube support arm (5")	0327 0700b
151	Tube support arm (100")	0327 0700a
152	Tube support arm GE	0327 0700d
153	Tube support arm Toshiba	0327 0700e
154		
155	Detent quick release assembly	0327 0720
156		
157	Screw M6x15 DIN912	2010 0018
158	Eccentric bushing	0322 0828
159		
160	Spacer GE	0322 0804
161	Spacer GE	0322 0806
162		
163	Ring	0325 0372
164	Intermediate plate	0325 0371
165	Protection ring	0325 0368
166	Spacer	0325 0367
167	Screw M5x16 DIN85	2090 0053
168	Bulb 24V 18W	3360 0002
169	Field light assembly	0325 0350c
170	LED gr	3000 0002
171	Switch	0006 0548
172	Handle	0322 0215
173	Konus (Comet)	0322 0279
174	LED ge	3000 0003
175	Control housing	0322 0245a
175a	Control housing USA	0322 0245b
176	Angle indicator	0325 0340
177	Mounting bracket	0325 0287
178	Flange bracket	0325 0269
179	Screw M6x10 DIN933	2020 0076
180	Bracket	0322 0192
181	Spacer	0322 0193
182	Screw M8x65 DIN912	2010 0113
183	Trim cover	0325 0320b
184	Cover	0325 0320a
185	Mounting bracket	0322 0229
186	Tape measure	0325 0349
187		
188		
189		
190	Guide for wiper	0322 0130
191	Clamp strip	0322 0132
192	Wiper	0322 0131

4.5 Name Plate Location

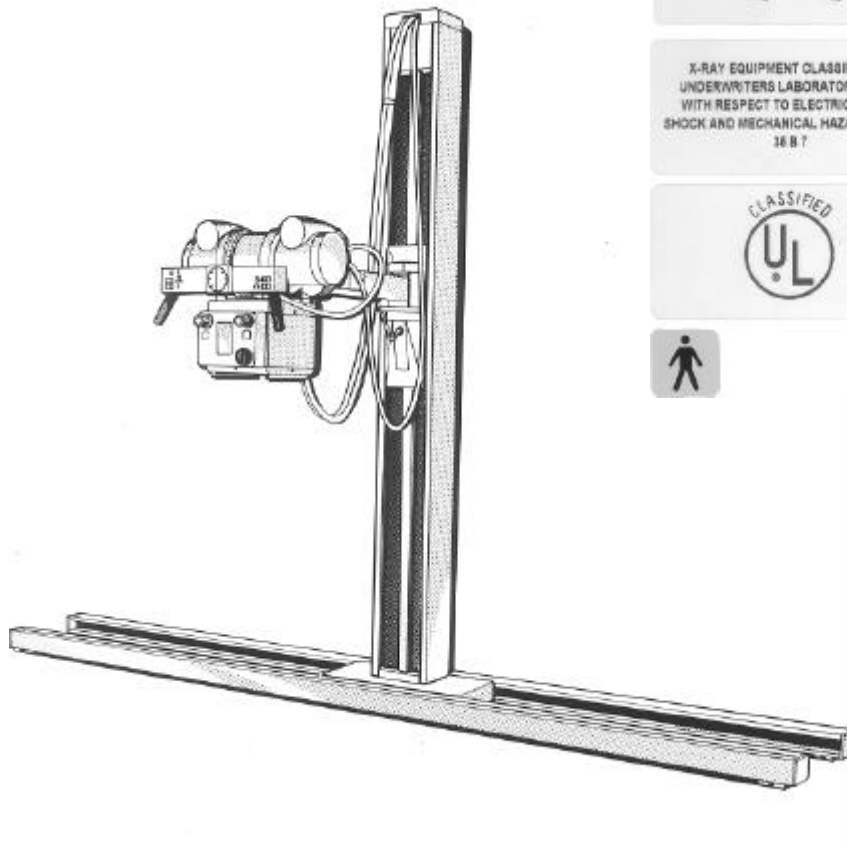

 <p>HANS PAUSCH Röntgengerätebau D-91056 Erlangen Graf-Zeppelin-Str. 1</p>	<p>Type <input type="text"/></p> <p>Fabr.Nr. <input type="text"/></p> <p>Datum <input type="text"/></p> <p>Spannung <input type="text"/> Volt</p> <p>Frequenz <input type="text"/> Hertz</p> <p>Strom <input type="text"/> Ampere</p> <p>Made in Germany</p>	<p>PAUSCH CORPORATION 808 Shrewsbury Avenue Tinton Falls, NJ 07724</p> <p>Model No. <input type="text"/></p> <p>Serial No. <input type="text"/></p> <p>Input <input type="text"/> Voltage</p> <p><input type="checkbox"/> Phases <input type="text"/> Hertz</p> <p><input type="text"/> Amperes</p> <p>Date Mtg. <input type="text"/></p> <p>This product complies with applicable standards under "21 CFR Sub-Chapter J"</p> <p>Made by BEANE P. (USA) at Graf-Zeppelin-Str. 1 91056 Erlangen Germany</p>
--	--	---



X-RAY EQUIPMENT CLASSIFIED BY UNDERWRITERS LABORATORIES INC.® WITH RESPECT TO ELECTRICAL FIRE, SHOCK AND MECHANICAL HAZARDS ONLY. 16 B 7

X-RAY EQUIPMENT CLASSIFIED BY UNDERWRITERS LABORATORIES INC.® WITH RESPECT TO ELECTRICAL FIRE, SHOCK AND MECHANICAL HAZARDS ONLY. 16 B 7



